

GYPROCK[®]

Everything else is just plasterboard

Shaft Systems

Lift, stairwell and service shaft design and installation guide



**PROFESSIONAL
SOLUTIONS**



CSR

CONTENTS

Introduction	2
Typical Applications for Gyprock™ Shaft Systems	3
System Performance	4
Advantages	5
Design Considerations	5
Gyprock™ Plasterboard & Accessories	6 – 8
Architectural Specification	9
System Selection	10 – 13
Shaftwall System Table	
Steel Stud System Table	
Laminated Service Shaft System Table	
Shaftwall System Installation	14 – 17
Wall Junction Details	17 – 20
Access Doorways	21
Lift Landing Doorways	22
Access Panels & Frames	23
Laminated System Installation Details	24 – 27
Contact, Safety & Warranty Information	28

INTRODUCTION

Gyprock™ Shaft Systems are non-loadbearing, fire resistant wall assemblies designed to encase lift shafts, stairwells and service ducting in low and high rise construction.

A comprehensive range of Gyprock™ Shaft Systems is available to accommodate most common applications. Systems include Shaftwall Systems for lifts, stairwells and service shafts, and Laminated Service Systems for service shafts.

Shaftwall Systems comprise 25mm thick Gyprock™ Shaft Liner Panel and 16mm Gyprock Fyrchek™ plasterboard supported by a frame of galvanised steel C-H studs, tracks or angles.

Laminated Service Systems comprise 3 layers of Gyprock Fyrchek™ plasterboard laminated together using screws or screws and glue, and incorporating perimeter steel angle framing.

Gyprock™ Shaft Systems are designed predominantly for erection from one side only. Walls are assembled from outside the shaft at each floor, eliminating the need for access or scaffolding within the shaft.

Gyprock™ Shaft Systems combine lightweight construction, rapid installation and drywall finishing techniques to offer significant cost savings to builders and developers. These benefits are of particular significance when used in conjunction with structural steel construction.

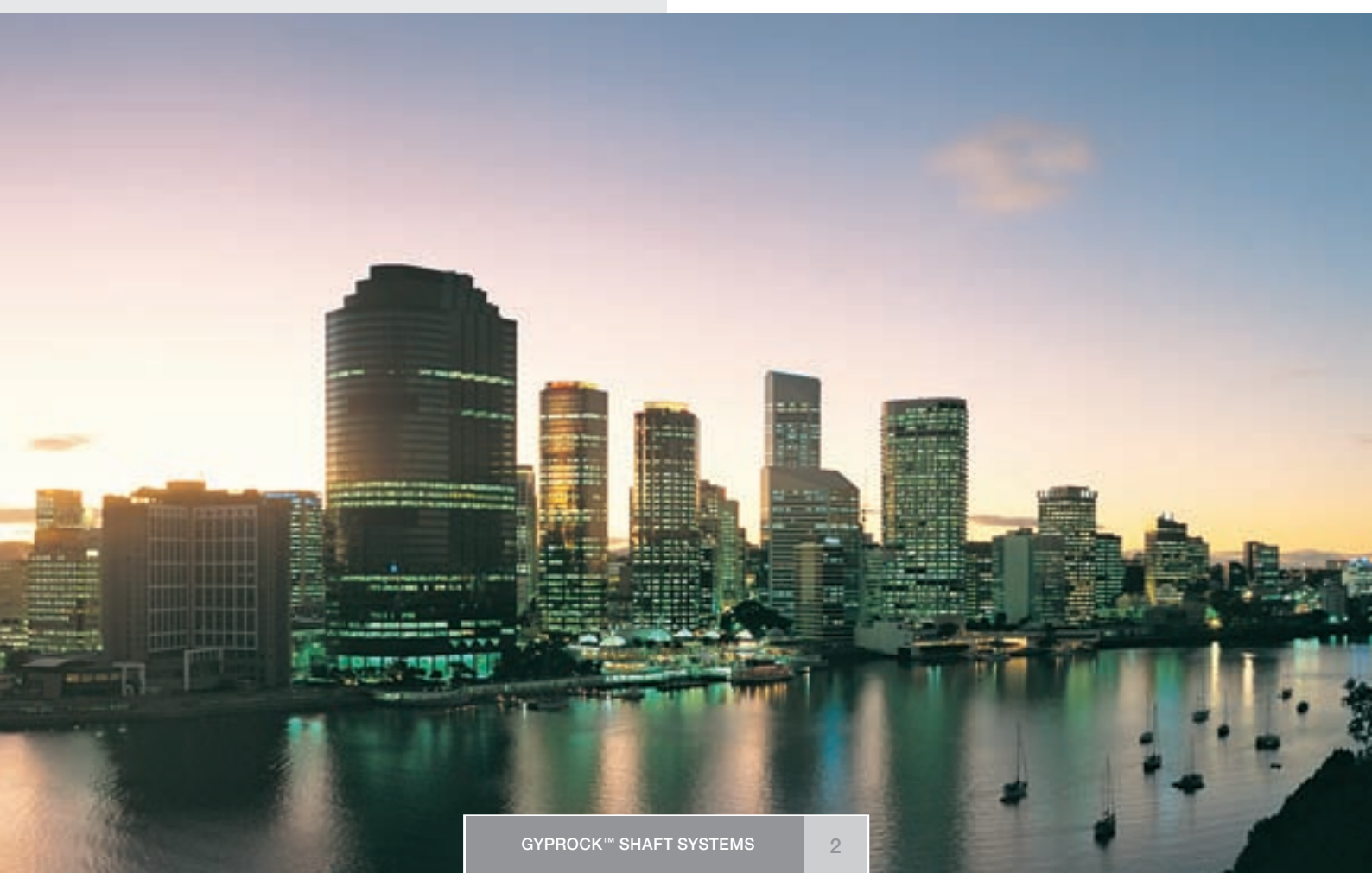

TYPICAL APPLICATIONS FOR GYPROCK™ SHAFT SYSTEMS

FIG 1: TYPICAL BUILDING CORE PLAN

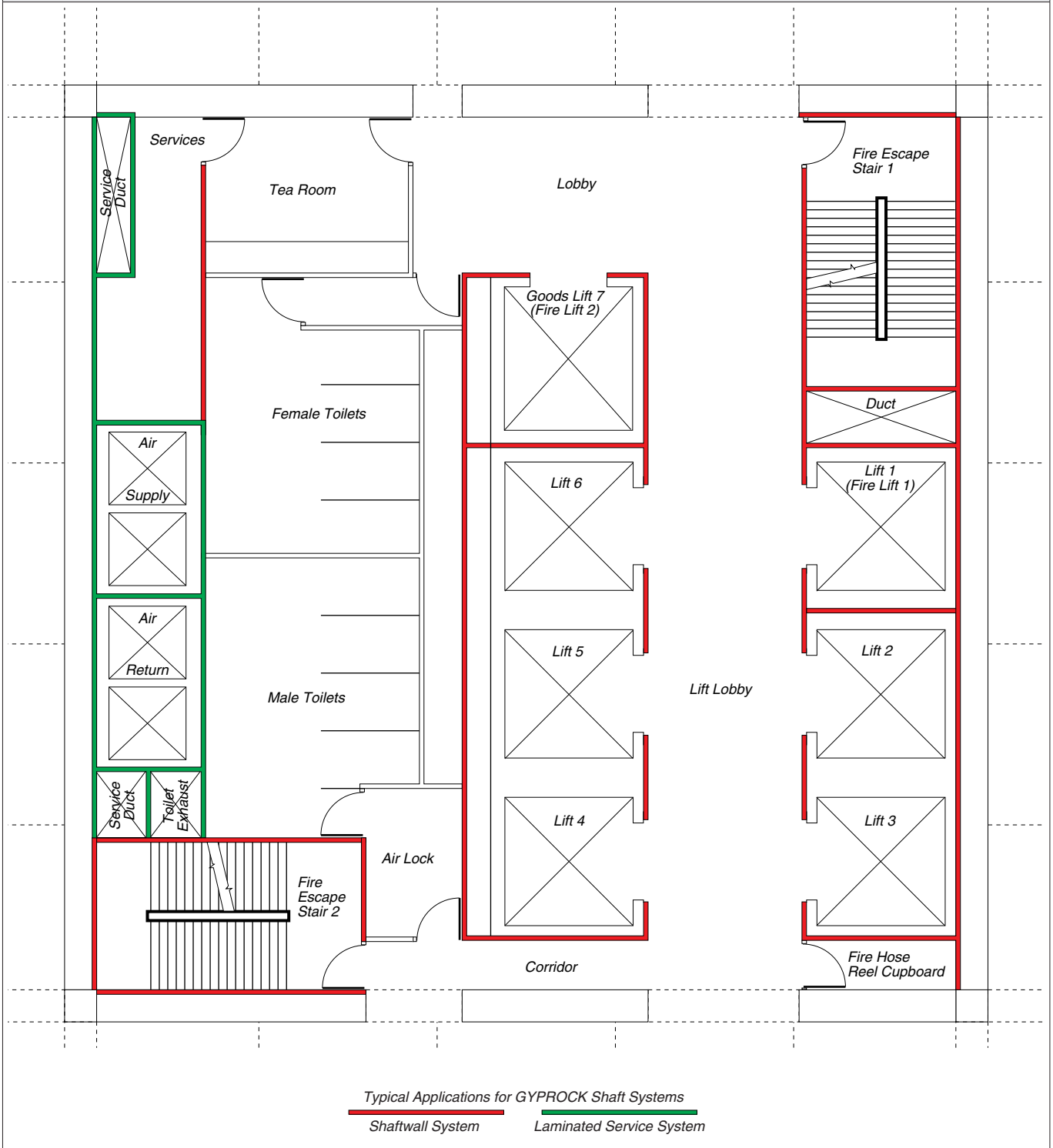

SYSTEM PERFORMANCE

Construction used to bound means of egress, such as walls enclosing lifts, stairwells and fire-isolated passageways, performs an important function should fire occur.

Such walls provide protection for the fire brigade entering the building to reach a fire, and to the occupants attempting to leave the building. These walls must offer proven fire resistance for the design fire period, including sufficient structural strength to fulfil these functions.

Service shafts are typically enclosures containing electrical, mechanical or hydraulic services between floor levels. Walls for these enclosures may be required to:

- Protect the services from fire.
- Prevent the spread of fire via the service duct.
- Provide acoustic separation between noisy services and building occupants.

The Building Code of Australia specifies the minimum fire resistance level and structural performance requirements of lightweight construction systems when used to protect building components in the various types of buildings.

Gyprock™ Shaft Systems are classified as 'lightweight construction' under the Building Code of Australia definition, and have been subjected to appropriate testing as required by the Code.

Fire Resistance

Gyprock™ Shaft Systems have been tested in accordance with Australian Standard AS1530 Part 4, and letters of opinion covering minor variations from tested prototypes have been obtained from recognised authorities.

The fire resistance levels quoted for Gyprock™ Shaft Systems apply for fire attack from either direction, despite their non-symmetrical nature.

Acoustic Performance

Various Gyprock™ Shaft System configurations have been laboratory tested for acoustic performance. Testing has been conducted in accordance with the relevant Australian or Overseas Standard applying at the time of testing.

Where test results are not available, estimates calculated by PKA Acoustic Consulting are provided.

The CSR Gyprock™ Acoustic Predictor

CSR Gyprock™ provides a service which can assist in determining the R_w ratings of stud walls lined with Gyprock™ plasterboard that are not published in this guide. Please telephone the CSR designLINK Service on 1800 621 117 for assistance.

Structural Performance

The Building Code of Australia – Specification C1.8 'Structural Tests for Lightweight Construction', details the tests to be applied and criteria to be satisfied by lightweight wall construction. These four tests are as follows –

Resistance to Static Pressure

Typical wall sections are subjected to a uniformly distributed load (or its equivalent) of 0.25kPa or 0.35kPa depending on the location of the wall and the class of the building in which it is used.

Gyprock™ Shaft Systems have the proven strength to resist these loads, which are typical of those experienced during the lifetime of the building.

Laminated Service Systems are suitable for 0.35kPa.

Refer to NATA Test Report N°MT12-90.

Gyprock™ Shaft Systems are not suitable for certain walls of Class 9B buildings which require 1.0kPa loading.

Resistance to Impact

A series of impacts from a 27.2kg sandbag are imposed on a typical wall section and must not cause permanent damage.

Gyprock™ Shaft Systems combine the structural efficiency of C-H studs or steel angle framing with the strength of plasterboard to satisfy this requirement.

Refer to NATA Test Report N°MT2-88.

Resistance to Surface Indentation

This test measures the surface hardness of the material.

Gyprock Fyrchek™ and Gyprock™ Shaft Liner Panel both satisfy the requirements of this test.

Refer to NATA Test Report N°MT8-89 and MT9-89.

Resistance to Repetitive Loads

The movement of high speed lift cars within the shaft of a high rise building exerts positive and negative air pressure forces on the walls enclosing the shaft. These forces have been known to damage rigid masonry enclosures over time.

This test simulates these forces by the imposition of one million cycles of a uniformly distributed load (or its equivalent) between 0 and 0.35kPa.

Gyprock™ Shaft Systems using C-H stud framing have been subjected to these dynamic tests and have the ability to flex in response to such loads without sustaining damage

Refer to NATA Test Report N°MT13-90.

ADVANTAGES

Rapid Installation

Gyprock™ Shaft Systems are rapidly installed from one side at each floor, with no need for access within the shaft.

Shafts are rapidly closed in, providing safe work areas for following trades.

As no scaffolding is required within shafts, lifts services can be installed early in the construction program, ready to move men and materials to higher floors as needed.

All components are screw or screw and adhesive fixed, and there is no need for welding or bolting.

Light Weight

Gyprock™ Shaft Systems weigh less than 50kg/m², or approximately 25% of the weight of equivalent masonry or concrete enclosures.

Weight reductions of this magnitude can result in significant cost savings through the complete structure, from structural columns and beams to footing and foundations.

Slender Walls

The reduced floor space required by Gyprock™ Shaft Systems means greater net floor areas are available for use/lease.

Easier Materials Handling

Large quantities of metal components and plasterboard sheeting can be transported to site, craned into position and stored on each floor ready for installation with a minimum of disruption to other trades.

Drywall Construction

Drywall construction methods eliminate the delays, mess and inconvenience associated with traditional wet trades, and allow the early decoration of finished walls.

DESIGN CONSIDERATIONS

BCA Requirements

Gyprock™ Shaft Systems are classed as 'Lightweight Construction' by the Building Code of Australia. Designers should ensure that selected wall systems satisfy the fire resistance and structural requirement of the Code for the applications proposed.

Air Movement/Pressures

Gyprock™ Shaft Systems used to enclose lift shafts or service ducts must have all perimeters and penetrations

effectively sealed with Gyprock™ Fire Mastic to eliminate whistling and sound leakage while maintain the stated fire resistance level.

Service Ducts

Gyprock™ Shaft Systems may be used as unlined return air ducts, providing surface air temperatures and humidities do not allow condensation to occur on the faces of the plasterboard linings or the metal framework. These systems are not recommended for use as unlined HVAC supply ducts/shafts.

Moisture

Exposure to excessive or continuous moisture or humidity should be avoided both during construction and in service.

Allowance needs to be made for the capping of shafts during the construction phase to ensure installations are not damaged by excessive rainwater.

Service Penetrations

Gyprock™ Shaft Systems incorporating access panels, fire dampers, plumbing penetrations and the like, must be detailed to ensure both their fire and structural integrity is maintained.

Fire Doors

Proprietary steel door frames as detailed on page 22 and 23 are ordered separately and supplied by the appropriate manufacturer.

Lift Equipment

Lift operating equipment should be mounted independently from the shaftwall system.

Structural

All Gyprock™ Shaft Systems are designed as non-loadbearing partitions. It is acceptable however to include loadbearing elements within the system cavity.

Gyprock™ Shaft Systems are not intended to provide resistance to in-plane loading (bracing).

Perimeter Fasteners

It is important that the project engineer approve the type, size and maximum spacing of perimeter fasteners to meet the design load requirements.

Track fasteners shall be capable of withstanding a minimum of 0.86kN single shear and 0.89kN bearing force.

GYPROCK™ PLASTERBOARD & ACCESSORIES

CSR Gyprock™ manufactures a diverse range of plasterboard sheet products for fire rated and non-fire rated applications. Refer to Table 1 for thickness and sheet size availability.

Fire Rated Plasterboards

Gyprock Fyrchek™ can be used in wall and ceiling systems where fire resistance is to be achieved and is also useful where improved acoustic performance is required. Gyprock Fyrchek™ is machine made sheet composed of a specially processed glassfibre reinforced gypsum core encased in a heavy duty liner board.

Gyprock FyrchekMR™ is primarily intended for walls and ceilings in 'wet area rooms' and for soffits and external eaves which must also achieve fire resistance. Gyprock FyrchekMR™ is machine made sheet composed of a specially processed glassfibre reinforced gypsum core encased in a heavy duty liner board. Both the core and the liner board are treated in manufacture to withstand the effects of high humidity and moisture.

Gyprock™ Shaft Liner Panel is a 25mm thick machine made sheet composed of a specially processed glass fibre reinforced gypsum core encased in a heavy duty liner board. Gyprock™ Shaft Liner Panel is specifically developed to enclose lift shafts, stairwells and service shafts in multi-storey construction. Gyprock™ Shaft Liner Panel can be used to achieve fire resistance in wall and ceiling systems.

Gyprock EC08™ Range. A first in the Australian plasterboard industry, the Gyprock EC08 range was developed to meet the changing needs of the green building market. The range is fully GECA accredited, including the premium EC08™ Complete which is Mould, Impact and Moisture resistant, and Fire and Acoustic rated. EC08™ Impact MR is Impact and Moisture resistant, and Fire and Acoustic rated. EC08™ Impact is a high performance Impact

board and is fire and acoustic rated. EC08™ Fire is fire and acoustic rated. EC08™Aqua is a moisture resistant board for use in green projects and EC08™ Partition is a partition grade board for use in green building.

Fire Resistance

Gyprock™ plasterboard products have been tested to AS1530.3, 'Simultaneous determination of Ignition, Flame Propagation, Heat Release and Smoke Release. See Table 2 for test results.

GYPROCK Product	EFHI	ASEA m ² /kg	Group Number
13 – 16mm Fyrchek™	0/0/0/3	<250	1
13 – 16mm FyrchekMR™	13/0/2/2	<250	1
25mm Shaft Liner Panel	0/0/0/3	<250	1
13mm EC08™ Fire	0/0/0/3	<250	1
13mm EC08™ Impact	0/0/0/3	<250	1
13mm EC08™ Complete	0/0/0/3	<250	1

NOTES: EFHI = Early Fire Hazard Indices (Ignitability/Spread of Flame/Heat Developed).
ASEA = Average Specific Extinction Area

Handling & Storage

All materials must be kept dry, preferably stored inside. Care should be taken to avoid sagging or damage to ends, edges and surfaces of sheets.

All Gyprock™ plasterboard must be stacked flat, properly supported on a level platform or on support members which extend the full width of the sheets and which are spaced at a maximum of 600mm centres.

If stored outside, sheets must be stored off the ground, stacked as previously detailed and protected from the weather.



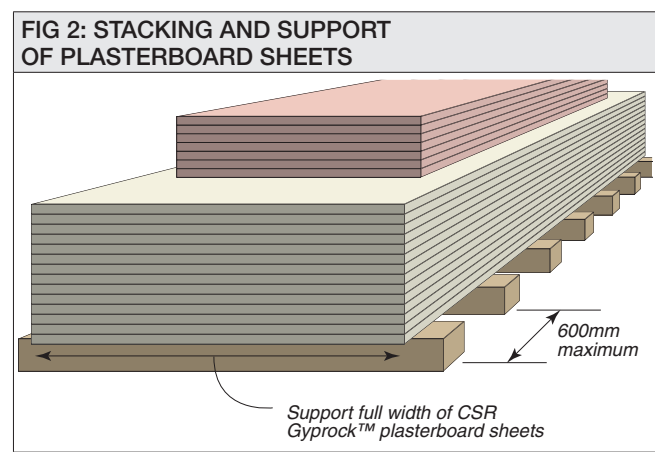

Gyprock™ Product	Thickness mm	Width mm	Mass kg/m ²
Fyrchek™	13	1200	10.5
	16	1200	12.5
FyrchekMR™	13	1200	10.7
	16	1200	13.5
Shaft Liner Panel	25	600	19.8
EC08™ Fire	13	1200	10.5
EC08™ Impact	13	1200	12.1
EC08™ Complete	13	1200	12.4

Call 13 17 44 to confirm available products and sizes for your region. Custom sizes may be available subject to minimum order. Lead times may apply

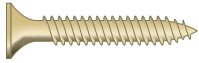

Fasteners

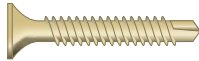
CSR Gyprock™ distributes a comprehensive range of screws for use with steel framing to accommodate most installation applications.

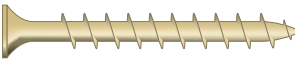
- N°6-18 Type 'S' Needle Point Screws (25mm or 40mm) for lightweight steel studs and furring channel up to 0.8mm thickness  
- N°6-18 Type 'S' Drill Point Screws (25mm or 40mm) for steel framing 0.8mm to 1.2mm thickness.  
- Gyprock™ Plasterboard Laminating Screws. 40mm x N°10. for laminating layers of plasterboard together at butt joints and control joints (where permitted).  

Sealants

Gyprock™ Fire Mastic must be used in fire rated systems where caulking is indicated, and is also recommended for caulking acoustic systems.

Promaseal IBS™ Rod (20mm and 29mm dia.) are to be used where indicated.

Jointing and Finishing

CSR Gyprock™ has a wide range compounds, cements and accessories for finishing plasterboard installations.

This manual does not provide plasterboard jointing and finishing details.

It should be noted that multi-layered systems only require jointing and finishing of the outer layer.

Information relating to the jointing and finishing of Gyprock™ plasterboard can be found in the Gyprock™ Plasterboard Residential Installation Guide, N°GYP547, or visit the CSR Gyprock website: www.gyprock.com.au

GYPROCK™ JOINTING AND FINISHING COMPOUNDS



Keep an eye out for our
NEW LOOK PACKAGING !

Steel Components

CSR Gyprock™ recommends steel building elements manufactured by Rondo Building Services Pty Ltd, for our systems.

Other brands of equivalent or better performance may be used.

It is the responsibility of the manufacturer of the steel component to substantiate equivalent or better performance than the recommended Rondo component.

General information on Rondo steel building components is provided throughout this manual.

Additional information can be obtained from the Rondo Building Services Pty Ltd office in your state, or telephone 1300 367 663.

TABLE 3: DESIGN PROPERTIES OF RONDO STEEL FRAMING COMPONENTS				
Component Type	Size	Stud BMT (mm)	Stud Depth (mm)	Standard Lengths (mm)
CH Stud	64CH55	0.55	64	3000, 3600
	64CH90	0.90	64	4500
	102CH55	0.55	102	3600, 4300
	102CH90	0.90	102	5500
E Stud	64E55	0.55	64	3000, 3600
	102E55	0.55	102	3600, 4300
J Track	64J80	0.80	64	3000
	102J80	0.80	102	3000
Deflection Head Track	64DT80	0.80	64	3000
	102DT80	0.80	102	3000
Jamb Stud	64JS80	0.80	64	3000
	102JS80	0.80	102	3600

E STUD

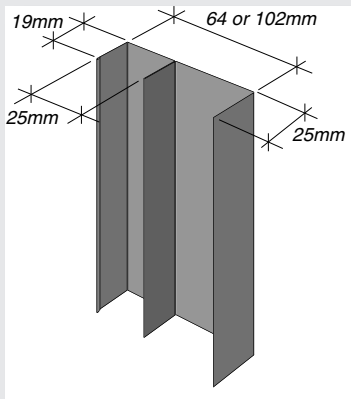

COMPONENT DESIGNATION

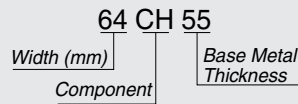

J TRACK

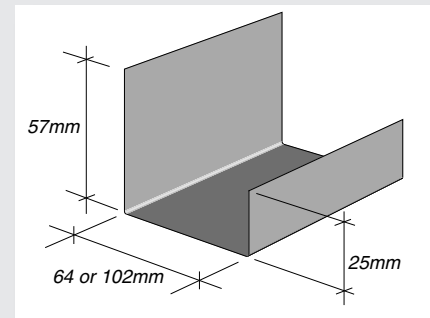

C-H STUD

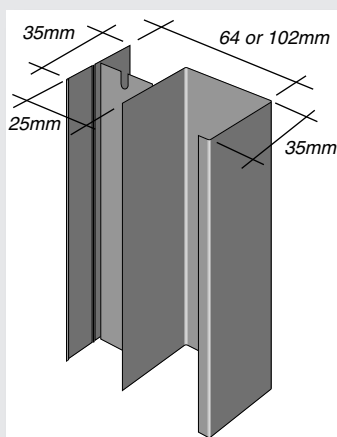

DEFLECTION HEAD TRACK

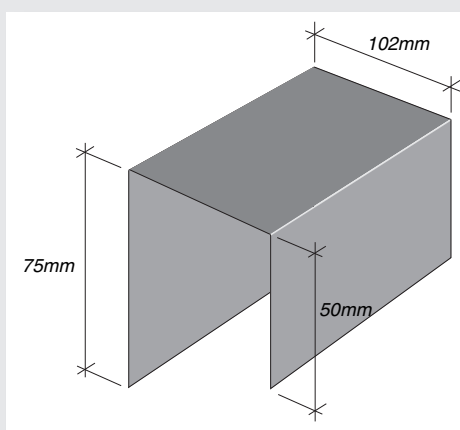

JAMB

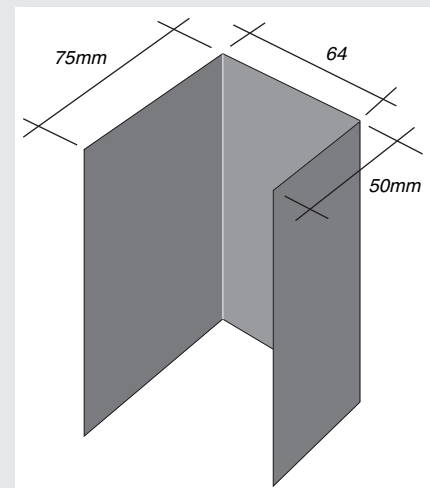

ARCHITECTURAL SPECIFICATION

Scope

The contractor shall furnish all materials, labour and equipment for the installation of the Gyprock™ plasterboard Shaft Systems where indicated on the drawings and/or as specified.

Materials

All lining materials shall be Gyprock™ plasterboard and accompanying accessories as manufactured or supplied by CSR Gyprock™.

Gyprock™ Plasterboard shall be manufactured to meet the dimensional requirements of AS/NZS2588 'Gypsum Plasterboard'.

Steel frame components shall be those manufactured by Rondo Building Services Pty Ltd (or products of equivalent or better performance).

Shaft Systems

The contractor shall supply and install the *lift shaft/stairwell/vertical duct* using Gyprock™ Shaft System *N°CSR..... in accordance with brochure N°GYP546, Gyprock™ Shaft Systems.

The installation shall satisfy the following performance criteria.

The wall shall have a *Fire Resistance Level – /...../..... in accordance with the requirements of AS1530.4.

The wall shall be designed to resist a uniformly distributed load of *.....kPa, in accordance with BCA Specification C1.8.

Installation shall also be carried out to the level specified for an acoustic performance of *R_w.....

*Cavity infill insulation shall bemm Bradford.....

Framing

Steel framing shall be installed in accordance with brochure N°GYP546, Gyprock™ Shaft Systems.

Shaftwall System framing shall consist of *64mm/102mm xmm BMT C-H Studs, E Studs, J-Tracks, Jamb-Struts and Deflection Tracks.

Studs shall be designed for a maximum span/deflection ratio of *1/240 or 1/360 and shall be installed at *.....mm maximum centres OR Laminated Service System framing shall consist of *25mm/50mm x 0.8mm BMT galvanised steel angle.

Track fasteners shall be capable of withstanding 0.86kN single shear and 0.89kN bearing force.

Plasterboard

Plasterboard lining shall comprise:

* One layer of 25mm Gyprock™ Shaft Liner Panel;

PLUS/OR layer(s) ofmm Gyprock Fyrchek™ plasterboard applied to *one/both side(s)* of the framing.

Plasterboard Fixing

Plasterboard shall be installed in accordance with brochure N°GYP546, Gyprock™ Shaft Systems.

Caulking

All gaps and penetrations shall be caulked in accordance with brochure N°GYP546, Gyprock™ Shaft Systems, using Gyprock™ Fire Mastic.

Jointing and Finishing

Where indicated on the drawings and/or as specified, jointing and finishing of the outer layer of Gyprock Fyrchek™ plasterboard shall be in accordance with brochure N°GYP547, Gyprock™ Plasterboard Residential Installation Guide.

* Insert or select appropriate specifications.

NOTE: This information can be downloaded from the CSR Gyprock™ website: www.gyprock.com.au

SYSTEM SELECTION

Shaftwall Systems

Gyprock™ Shaftwall Systems constructed with C-H Stud framing can be selected from Table 4.

These systems are most appropriate for lift shafts and stairwells, and for service ducts which are outside the dimensional range of the laminated systems detailed below.

TABLE 4: MAXIMUM PERMITTED HEIGHT OF C-H STUDS (mm)						
Component Designation	Stud Spacing mm	Maximum Height of Studs – mm				
		FRL – /120/120 (CSR 971)			FRL – /60/60 (CSR 970) FRL – /90/90 (CSR 977)	
		Uniformly Distributed Load (UDL)				
		0.25kPa	0.35kPa	0.5kPa	0.25kPa	0.35kPa
64CH55	600	3600	3400	2660	2950	2640
64CH90	600	3900	3890	3430	3460	3090
102CH55	600	4300	3800	2660	4300	3800
102CH90	600	4800	4800	4400	4800	4510

A TYPICAL SHAFTWALL SYSTEM DURING CONSTRUCTION FOR A LIFT APPLICATION



Laminated Service Systems

Laminated service systems consist of three plasterboard leaves laminated together. They rely on support at each end of the wall as well as at the top and the bottom. They are not suitable for lift shafts.

There are three Gyprock™ Laminated Service Systems which can provide Fire Resistance Levels (FRL) of –/90/90 or –/120/120. Two plasterboard fixing methods, (screw only fixing or screw and adhesive fixing) cater for wall heights up to 3.6m and wall widths up to 3.0m.

The appropriate Gyprock™ Laminated Service system can be selected based on the required fire resistance level (FRL) and the required enclosure wall height and width.

Table 5 details the maximum permitted wall dimensions for each system and construction method.

TABLE 5: MAXIMUM PERMITTED WALL HEIGHT/ WIDTH UNIFORMLY DISTRIBUTED LOAD (UDL) – 0.35kPa.

System N°	Wall Height (maximum)			
	2400	3000	3600	7200
	Wall Width (maximum)			
CSR967-S	1200	1200	1200	N/A
CSR968-S	1200	1200	1200	1200
CSR967-SA	2200	2100	2000	N/A
CSR968-SA	3100	2700	2600	1200
CSR969-SA	4200	3200	3000	N/A

-S = Screw Only Plasterboard Fixing
 -SA = Screw and Adhesive Plasterboard Fixing
 N/A = Not Applicable

SERVICE SHAFT WITH PERIMETER ANGLE FRAME FIXED



FIRST LAYER OF GYROCK FYRCEK AND PERIMETER FRAMING FIXED



GYPROCK LAMINATED SERVICE SYSTEM AFTER COMPLETION

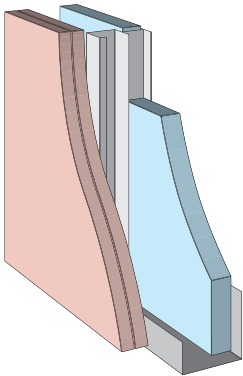
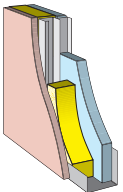
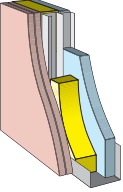
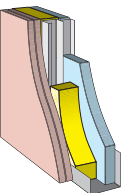

Steel Frame Internal Wall Systems – Shaft Wall

SYSTEM SPECIFICATION			TYPICAL LAYOUT (CSR 971 shown)		ACOUSTIC OPINION PKA-052
<ul style="list-style-type: none"> Lining material as per system table. 64 or 102mm C-H Metal Studs at 600mm maximum centres. Lining material as per system table. <p>NOTE: Acoustic performance valid for studs of 0.5mm BMT</p>					
FRL Report/Opinion	SYSTEM N°	WALL LININGS	STUD DEPTH mm	64	102
			CAVITY INFILL (Refer to Section 'A')	R _w / R _w +C _{tr}	
- /60/60 BRANZ LOP 493	CSR 970 	<i>BETWEEN STUDS</i> <ul style="list-style-type: none"> 1 x 25mm GYPROCK SHAFT LINER PANEL. <i>SIDE ONE</i> <ul style="list-style-type: none"> 1 x 16mm GYPROCK FYRCHEK plasterboard. 	(a) Nil	38/31	42/35
			(b) 50 GW Partition 11kg	43/34	47/38
			(c) 75 GW Partition 14kg	-	49/40
			(d) TSB3/ASB3 Polyester	42/35	46/39
			(e) 60 Soundscreen™ 1.6	-	48/38
			WALL THICKNESS mm	80	118
- /90/90 FAR3637	CSR 977 	<i>BETWEEN STUDS</i> <ul style="list-style-type: none"> 1 x 25mm GYPROCK SHAFT LINER PANEL. <i>SIDE ONE</i> <ul style="list-style-type: none"> 2 x 13mm GYPROCK FYRCHEK plasterboard. 	(a) Nil	41/34	46/40
			(b) 50 GW Partition 11kg	46/37	51/43
			(c) 75 GW Partition 14kg	-	53/45
			(d) TSB3/ASB3 Polyester	45/38	50/44
			(e) 60 Soundscreen™ 1.6	-	52/43
			WALL THICKNESS mm	90	128
- /120/120 Test SI 1517	CSR 971 	<i>BETWEEN STUDS</i> <ul style="list-style-type: none"> 1 x 25mm GYPROCK SHAFT LINER PANEL. <i>SIDE ONE</i> <ul style="list-style-type: none"> 2 x 16mm GYPROCK FYRCHEK plasterboard. 	(a) Nil	41/34	46/40
			(b) 50 GW Partition 11kg	46/37	51/43
			(c) 75 GW Partition 14kg	-	53/45
			(d) TSB3/ASB3 Polyester	45/38	50/44
			(e) 60 Soundscreen™ 1.6	-	52/43
			WALL THICKNESS mm	96	134

Steel Stud Systems

(With Alternative Installation Method)

For system specifications, please refer to 'The Red Book Fire and Acoustic Design Guide' N°GYP500.

For installation details, please refer to page 27 in this guide.

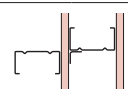
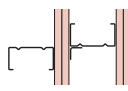
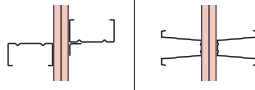
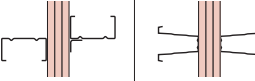
FRL	SYSTEM N°	WALL LININGS	CONSTRUCTION TYPE	
- /60/60 and 30/30/30 - /90/90 and 60/60/60	CSR 050 CSR 055	<ul style="list-style-type: none"> 1 + 1 x 13mm Gyprock Fyrchek™ plasterboard. 1 + 1 x 16mm Gyprock Fyrchek™ plasterboard. 		
- /120/120 and 90/90/90 - /180/180 and 120/120/120	CSR 075 CSR 080	<ul style="list-style-type: none"> 2 + 2 x 13mm Gyprock Fyrchek™ plasterboard. 2 + 2 x 16mm Gyprock Fyrchek™ plasterboard. 		
- /30/30 and 30/30/30 - /60/60 and 60/60/60	CSR 090 CSR 091	<ul style="list-style-type: none"> 2 x 13mm Gyprock Fyrchek™ plasterboard. 2 x 16mm Gyprock Fyrchek™ plasterboard. 		
- /90/90 and 90/90/90 - /120/120 and 120/120/120	CSR 092 CSR 093	<ul style="list-style-type: none"> 3 x 13mm Gyprock Fyrchek™ plasterboard. 3 x 16mm Gyprock Fyrchek™ plasterboard. 		

Steel Frame Internal Wall Systems – Laminated Services

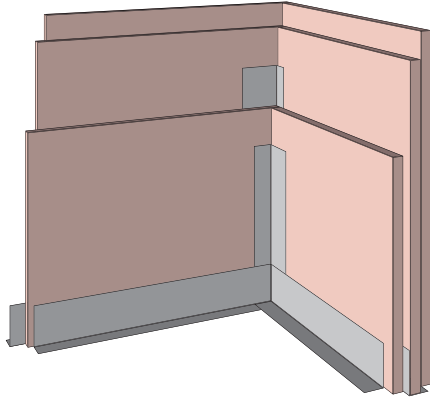
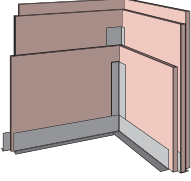
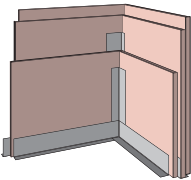
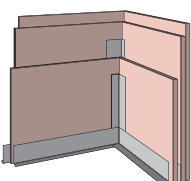
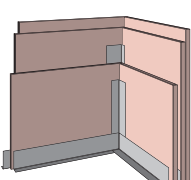
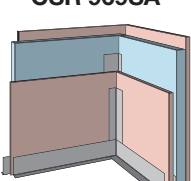
SYSTEM SPECIFICATION		TYPICAL LAYOUT (CSR 967 shown)			ACOUSTIC OPINION
<ul style="list-style-type: none"> Perimeter framing 25/50 x 50 x 0.7 BMT steel angle. 3 x GYPROCK FYRCHEK/SHAFT LINER PANEL laminated with screws (S), or screws and full cover adhesive (SA). 					PKA-052
FRL Report/Opinion	SYSTEM N°	WALL LININGS	CAVITY INFILL (Refer to Section 'A')	R _w	
- /90/90 WFRA 21898	CSR 967S 	<ul style="list-style-type: none"> 3 x 13mm GYPROCK FYRCHEK plasterboard (screw fixing). 	(a) Nil	35	
- /90/90 WFRA 21898	CSR 967SA 	<ul style="list-style-type: none"> 3 x 13mm GYPROCK FYRCHEK plasterboard (screw & adhesive fixing). 	(a) Nil	35	
- /120/120 WFRA 21898	CSR 968S 	<ul style="list-style-type: none"> 3 x 16mm GYPROCK FYRCHEK plasterboard (screw fixing). 	(a) Nil	36	
- /120/120 WFRA 21898	CSR 968SA 	<ul style="list-style-type: none"> 3 x 16mm GYPROCK FYRCHEK plasterboard (screw & adhesive fixing). 	(a) Nil	36	
- /120/120 WFRA 21898	CSR 969SA 	<ul style="list-style-type: none"> 1 x 16mm GYPROCK FYRCHEK plasterboard. 1 x 25mm GYPROCK SHAFT LINER PANEL. 1 x 16mm GYPROCK FYRCHEK plasterboard (screw & adhesive fixing). 	(a) Nil	37	

SHAFT WALL SYSTEM INSTALLATION

Introduction

Gyprock™ Shaft Walls are most commonly installed from one side only (known as the storey side), progressively installing the 25mm Shaft Line Panels and C-H studs before applying the finishing layer/s of 16mm Gyprock Fyrchek™ to the storey side.

Some wall systems, such as those used to enclose stairwells, require access to the shaft side of the wall for installation of a finishing layer.

Safety

Where walls are to be erected around open shafts ensure that adequate safety measures are taken.

Framing

- Cut both the floor and soffit J tracks 20mm shorter than the actual length of the wall.
- Cut the narrow flange off both ends of the floor and soffit J tracks for a distance of 60mm maximum. Refer to FIG 3.
- Accurately align the floor and soffit tracks according to the wall layout. Position the tracks with the narrow flange facing the storey side.
- Secure the floor and soffit tracks with fasteners at 100mm maximum from ends and at 600mm maximum centres. Refer to Page 5 for fastener performance requirements.
- Cut the end stud 20mm shorter than the wall height. Position the stud with the 25mm face to the storey side.
- Fix the end stud to the wall with fasteners at 100mm maximum from the ends and at 600mm maximum centres.
- With steel frame construction, tracks and studs should be attached to steel columns and beams before the structural members are independently fire rated.
- C-H studs should be cut 13mm shorter than the wall height to allow a gap at the top of the studs.

FIG 3: DETAIL AT ENDS OF FLOOR & SOFFIT TRACKS

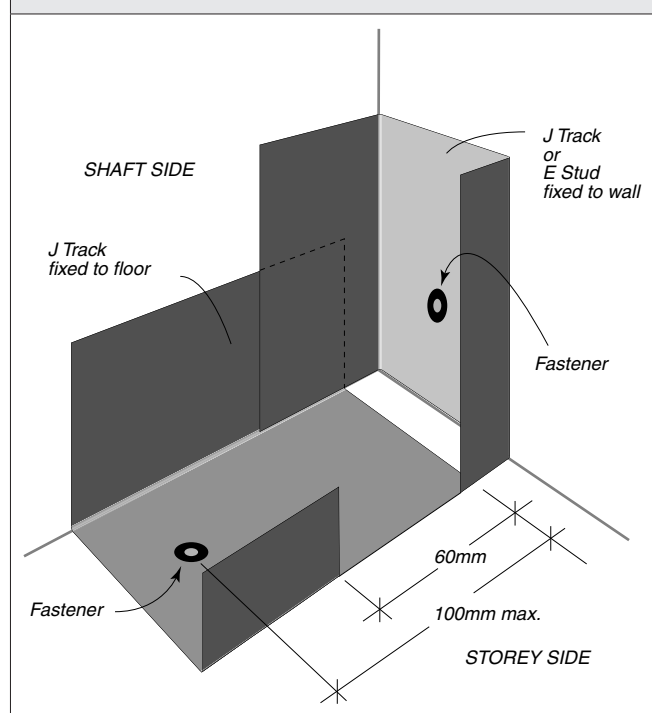

Shaft Liner Panel

- Cut the 25mm thick Gyprock™ Shaft Liner panel 25mm shorter than the overall wall height.
- Position the first liner panel vertically between the floor and soffit tracks, pushing the panel hard against the web of the end stud, leaving the 25mm gap at the top.
- When using J track as an end stud, screw fix the liner panels to the wide flange of the J track with 45mm screws at 300mm centres. Alternatively, E stud can be used. Refer to page 18 for details.
- Position the first C-H stud inside the floor and soffit tracks, fitting the 'H' section of the stud hard against the trailing edge of the Shaft Liner Panel already in position.
- Insert the next 25mm Shaft Liner Panel inside the floor and soffit tracks, pushing the panel hard against the web of the 'H' section of the C-H stud.
- Repeat this process until the last panel is to be installed.
- Fold the narrow flange of the bottom track over to allow for the last liner panel to be installed.
- Fix the J track to the wall with fasteners at 100mm maximum from the ends and at 600mm maximum centres.
- Cut the last Shaft Liner Panel 20mm short of the remaining width, and insert into the C-H stud. Screw fix to the end stud at 300mm centres.
- Pack the 20mm gap between the end stud and the last Shaft Liner Panels with 29mm diameter IBS backing rod. Refer to FIG 8.
- Pack the 25mm gap at the top of the Shaft Liner Panels with 29mm diameter IBS backing rod.

Alternative Installation Method for Last Panel

- Fold the narrow flange of the bottom track over to allow for the last liner panel to be installed.
- Place the end E stud over the vertical edge of the last Shaft Liner Panel and insert the panel at an angle into the 'H' section of the last C-H stud. Refer to FIG 9.
- Position the panel against the wide flange of the floor and soffit tracks.
- Attach the end stud to the wall with fasteners at 100mm maximum from ends and at 600mm maximum centres.

Butt Joints

- Where wall heights exceed the maximum available length of Gyprock™ Shaft Liner Panel, butt joints should be positioned within the upper or lower third of the wall. These liner panel joints should be reinforced with horizontal sections of C-H stud and joints in adjacent panels staggered to avoid a continuous horizontal joint. Refer to FIG 19 for details.

FIG 4: EXPLODED VIEW OF INSTALLATION ORDER

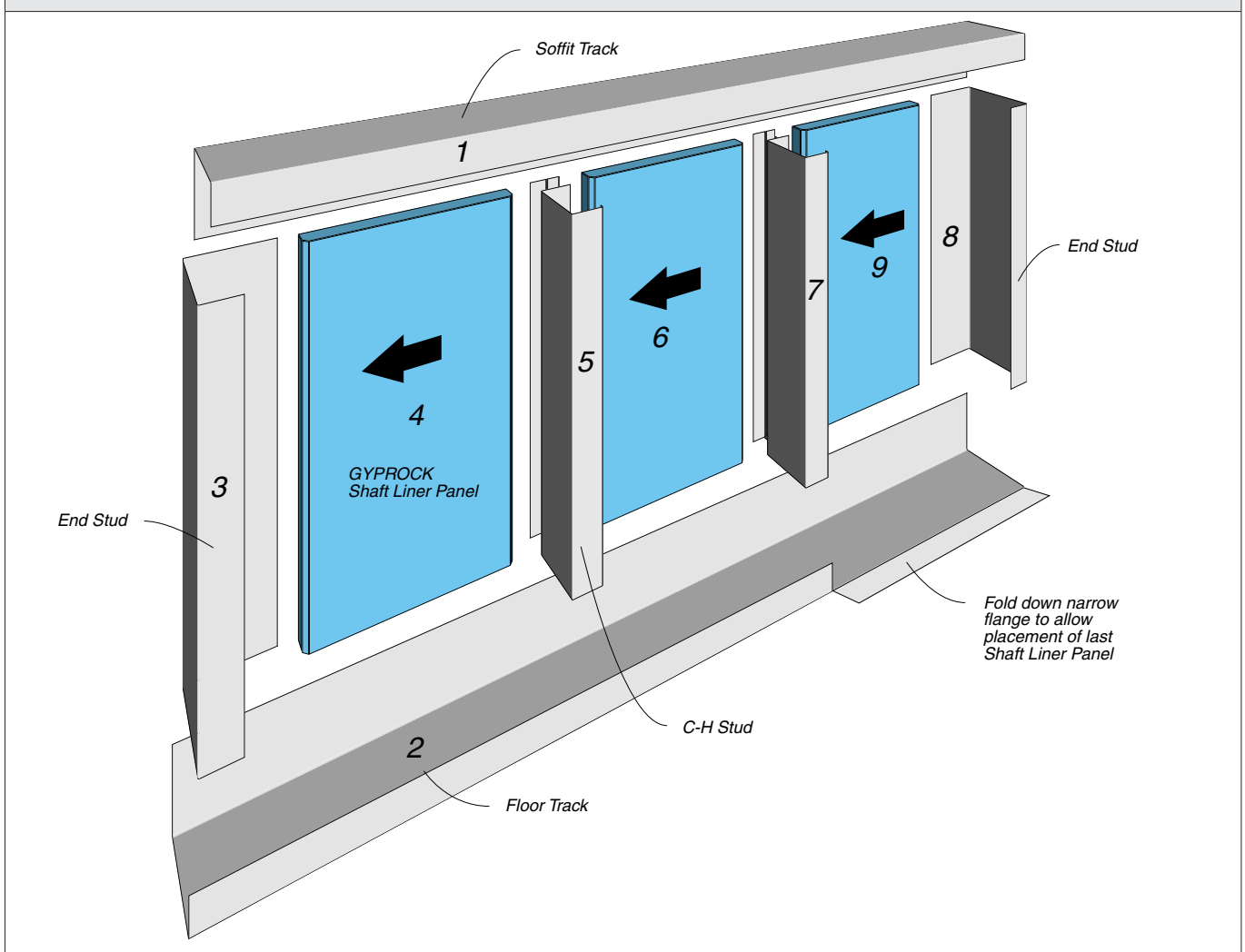

FIG 5: GYPROCK™ SHAFT LINER PANEL

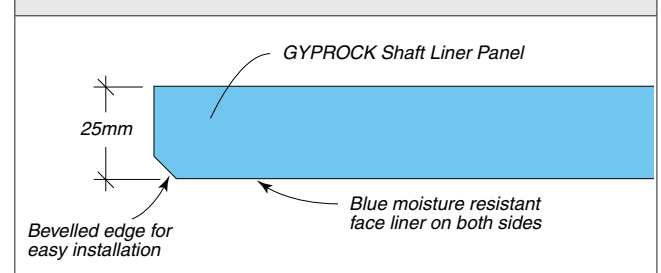
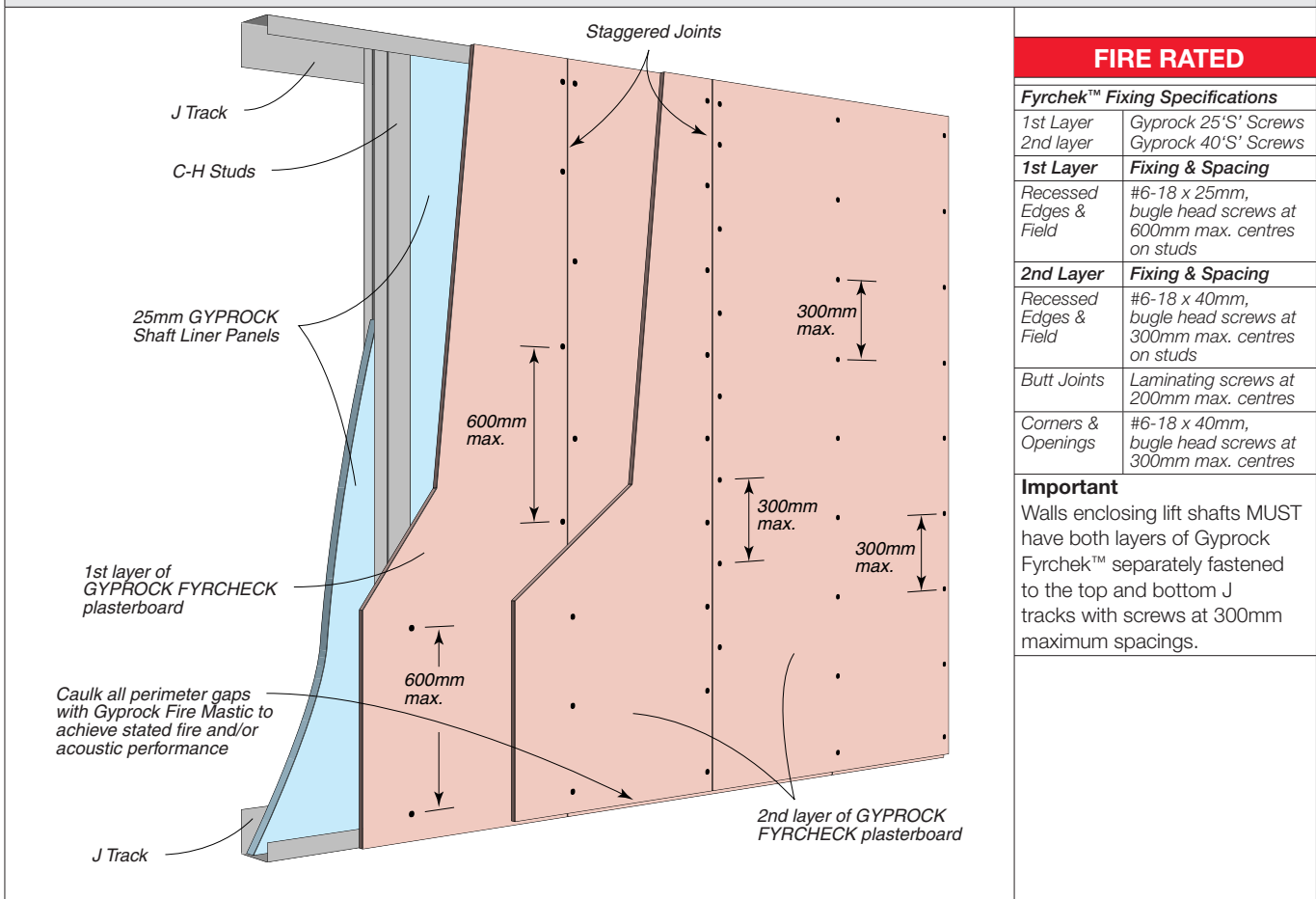

FIG 6: INSTALLATION DETAIL FOR SHAFTWALL SYSTEMS



Notes on Fixing Fyrcheck Plasterboard

- Offset joints in adjacent layers or layers on opposite sides of the wall by one stud.
- Cut sheets as necessary to provide 6-10mm clearance at the head and ends of the wall, and a 6mm gap at the bottom of the outer layer sheets.
- Do not fix sheets to the top and bottom tracks except for walls enclosing lifts.
- If butt joints are required, they must be staggered by 600mm min. between layers, between adjacent sheets and on opposite sides of the wall. Joints must be either backed by noggings and screw fixed at 200mm max. centres, or fixed with laminating screws at 200mm max. centres.
- Place edge fasteners at 10 to 16mm from sheet edge.

Fixing Procedure Double Layer Systems

For fastener specifications refer to FIG 6.

First Layer

- Apply sheets vertically with paper bound edges parallel with studs and with recess joints centred on stud flanges.
- Press the sheet firmly against the studs and screw fix at 100mm maximum from top and bottom of sheet, and at

600mm maximum centres along recessed edges, at all angles and around openings.

Second Layer

- Cut the first sheet to half width so that joints in the second layer do not align with joints in the first layer.
- Apply sheets vertically, leaving a 6mm gap between the bottom of the sheet and the floor, at the head and ends of the wall and screw fix at 100mm maximum from top and bottom of sheet, and at 300mm maximum centres to all studs.
- Screw fix at all angles and around openings at 300mm maximum centres.

Single Layer Systems

- Fix single layer systems as per the details for the second layer of double layer systems.

Single Layer Systems Lined Both Sides

- Install the plasterboard to the first side as per the procedure detailed for the second layer. Do not fix sheets to intermediate studs at this time.
- Start the second side with a half width sheet so that joints on opposite sides of the wall are located on different studs.
- Screw fix this and subsequent full width sheets to all studs at 100mm maximum from top and bottom of sheet, and at 300mm maximum centres to all studs.

- Return to the first side and screw fix plasterboard to intermediate studs at 100mm maximum from top and bottom of sheet, but not through tracks, (see notes) and at 300mm maximum centres.

Sealants

Fill all perimeter gaps with Gyprock™ Fire Mastic to the depth of one sheet.

Jointing

Fire rated shaft systems must be jointed with perforated paper tape and standard Gyprock™ jointing techniques in accordance with brochure N°GYP547, Gyprock™ Plasterboard Residential Installation Guide.

Tape and set face layer joints of Gyprock Fyrchek™ plasterboard only.

Corners formed by Gyprock Fyrchek™ must be taped and set or reinforced with corner beads.

WALL JUNCTION DETAILS

Junctions with Masonry Walls

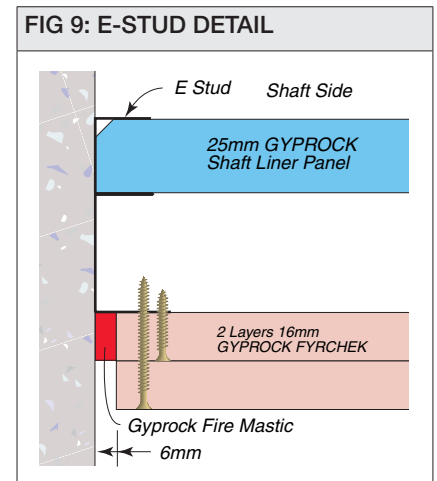
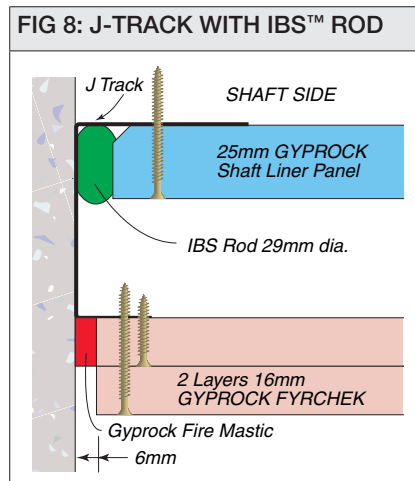
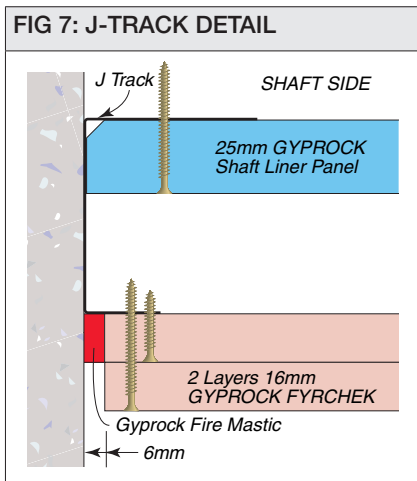

Junctions with Stud Walls

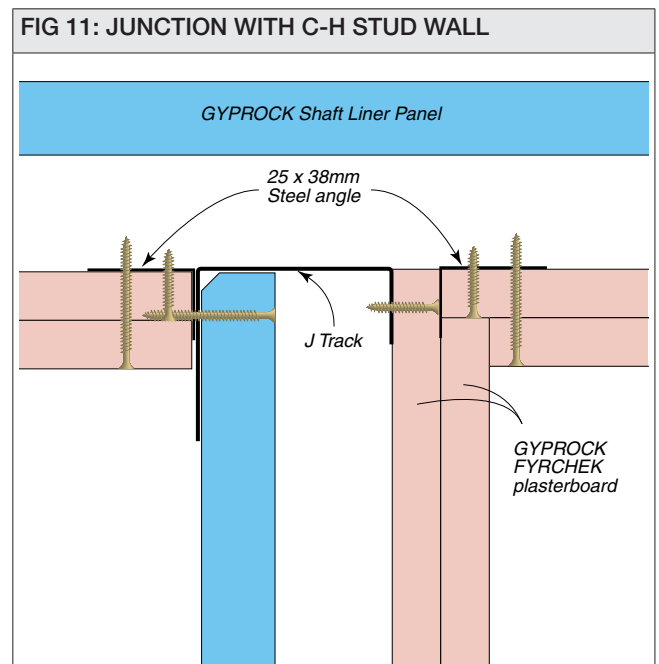
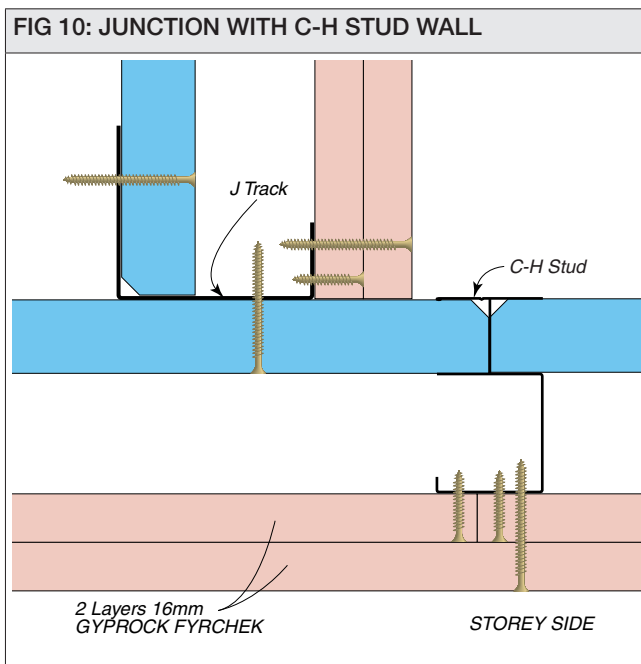

FIG 12: INSIDE CORNER DETAIL

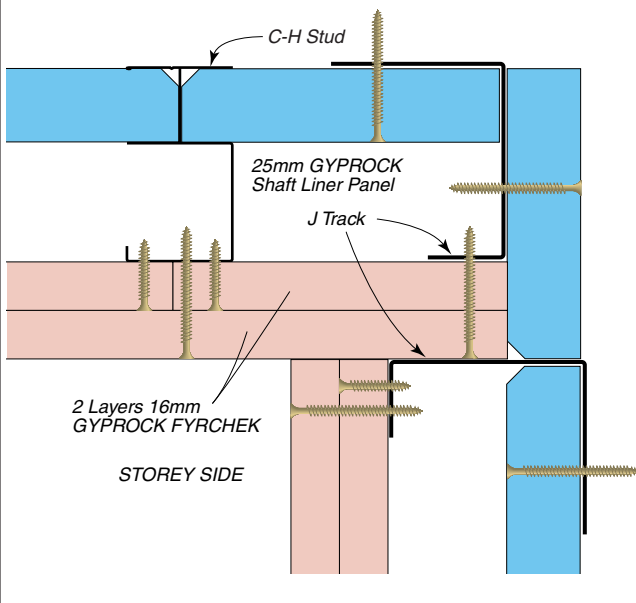

FIG 15: OUTSIDE CORNER DETAIL

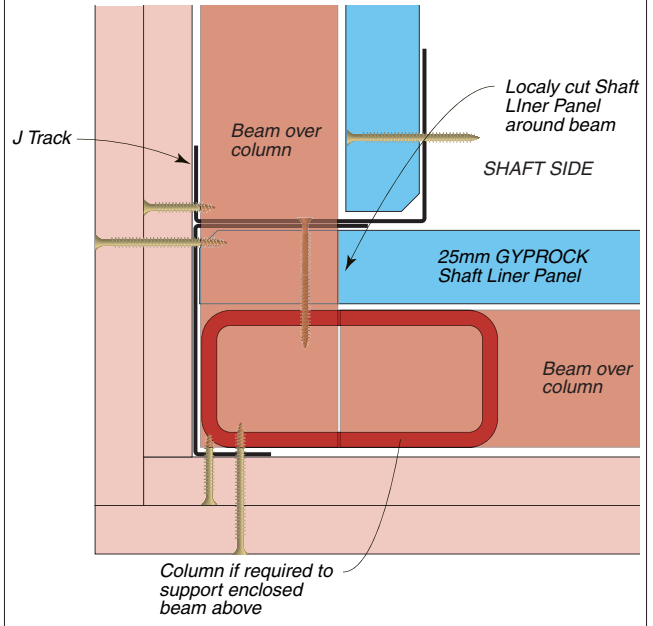

FIG 13: ANGLED CORNER DETAIL

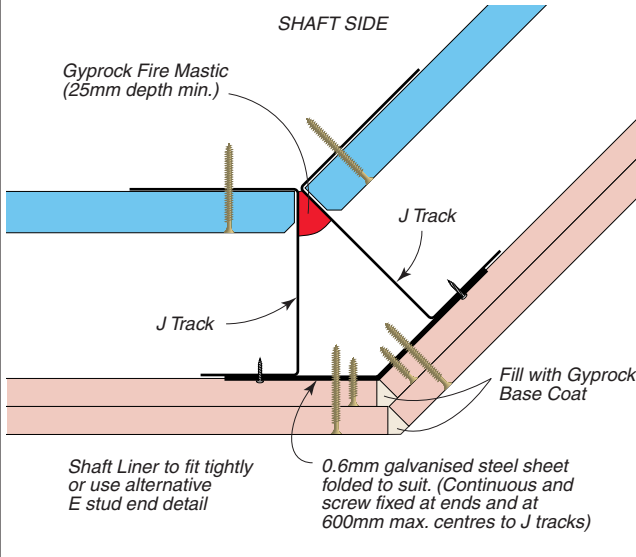

FIG 16: COLUMN FIXING DETAIL

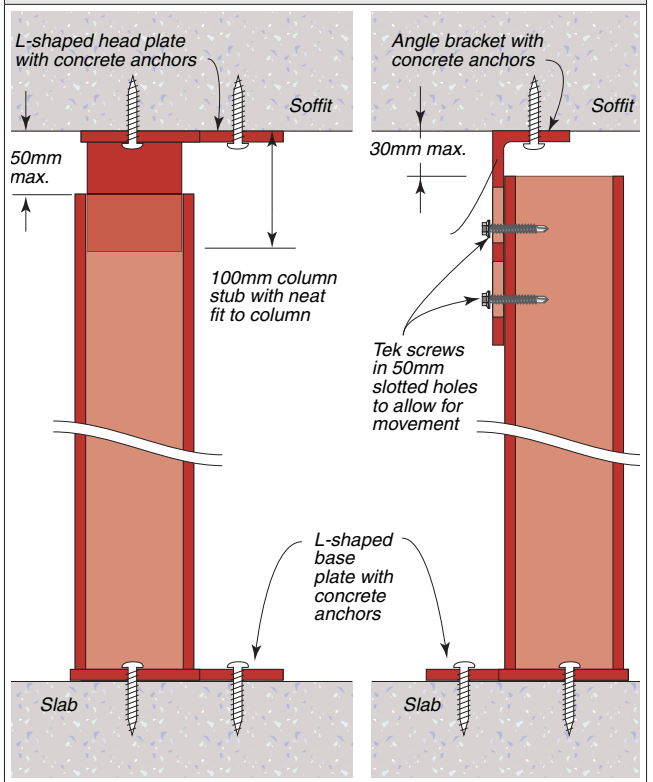

FIG 14: ENCLOSED STEEL BEAM DETAIL

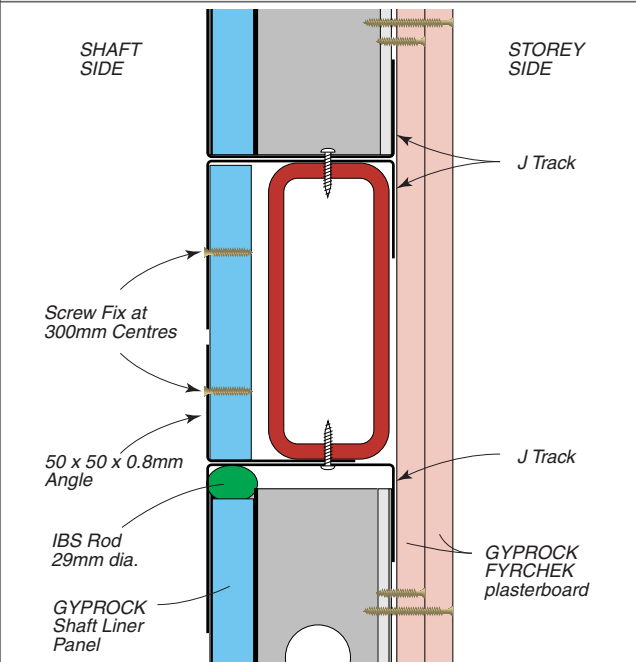

FIG 17: HEAD & BASE DETAIL

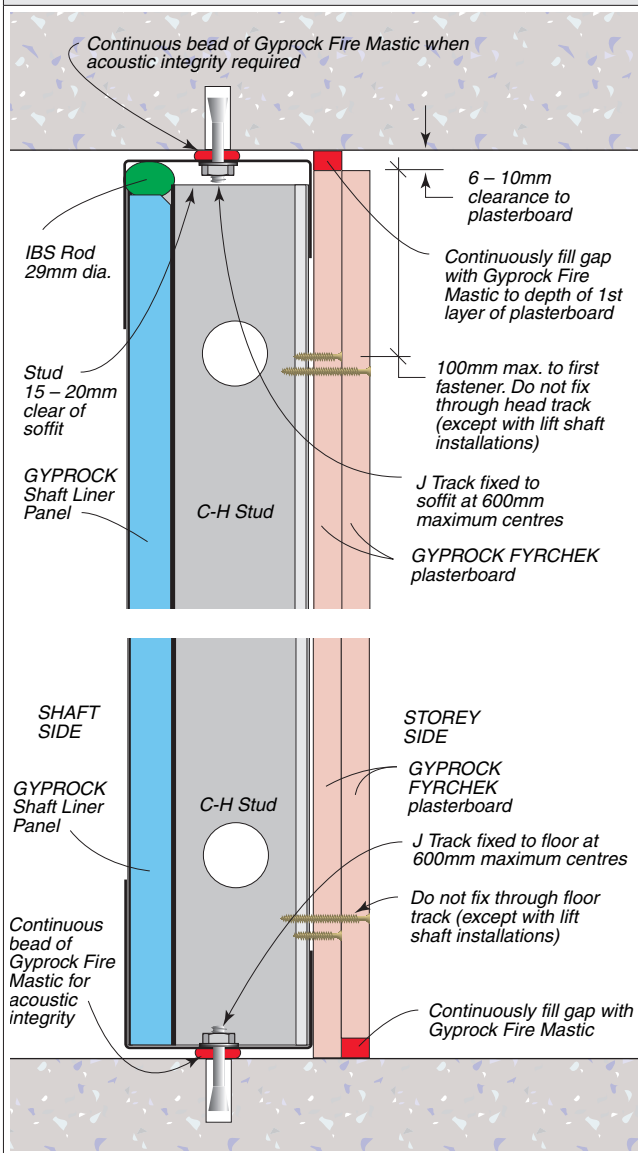

FIG 18: JUNCTION OF - /120/120 SHAFTWALL SYSTEM TO TIMBER FLOOR (WHERE TIMBER FRAMING IS PERMITTED)

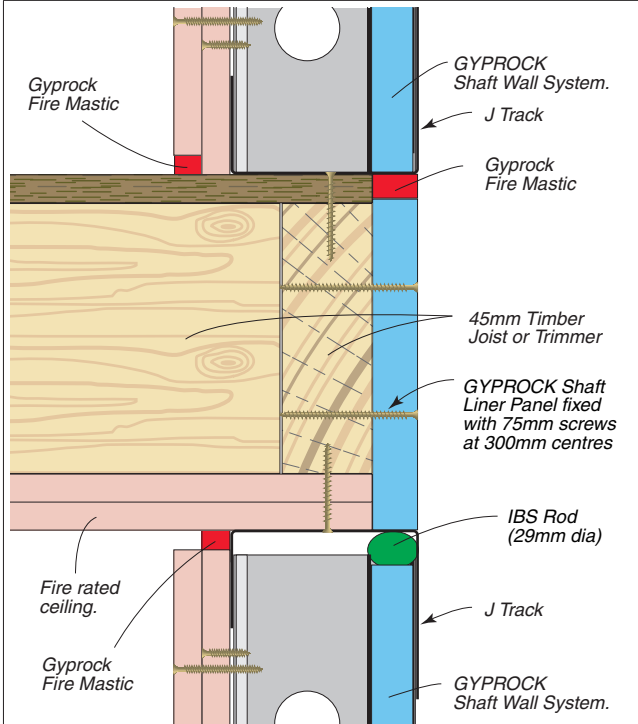
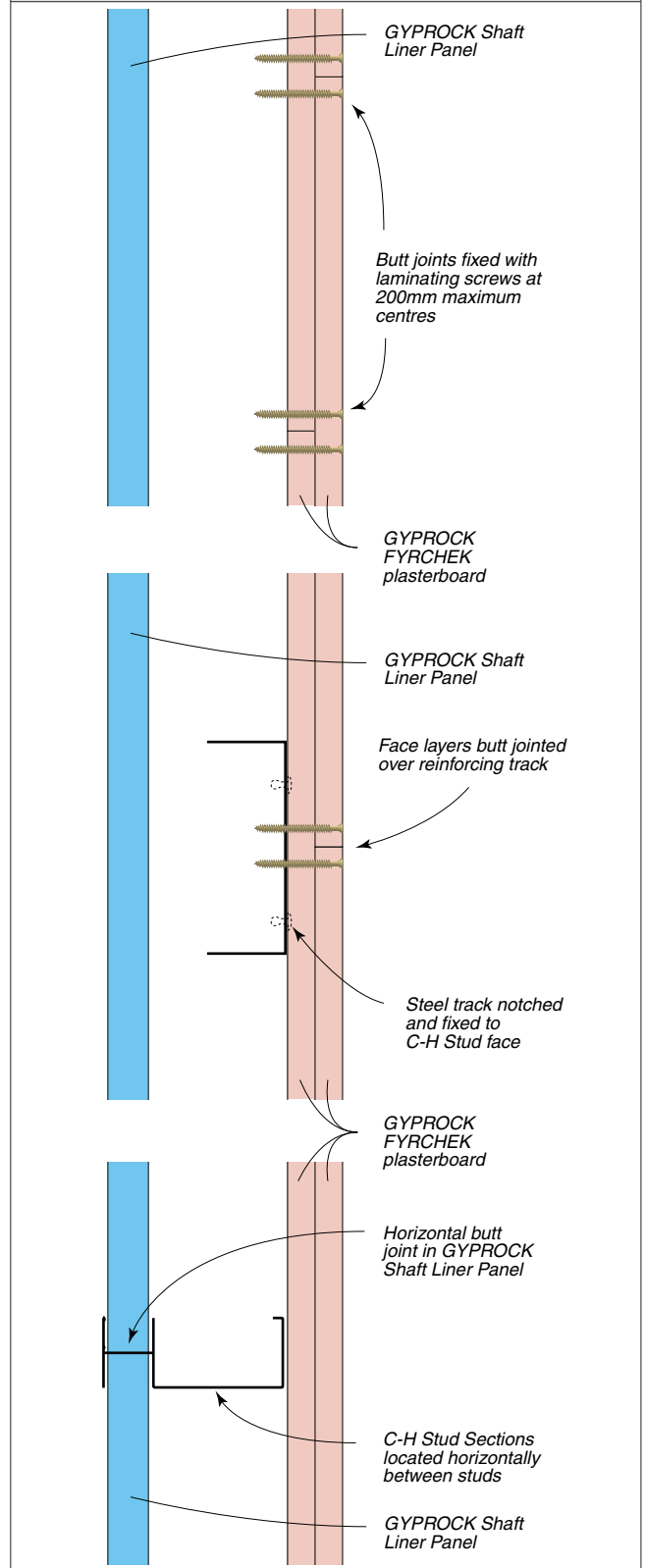

FIG 19: ALTERNATIVE DETAILS FOR HORIZONTAL BUTT JOINTS



Wall Junctions with structural Steel Members

FIG 20: WALL JUNCTION AT UNIVERSAL COLUMN

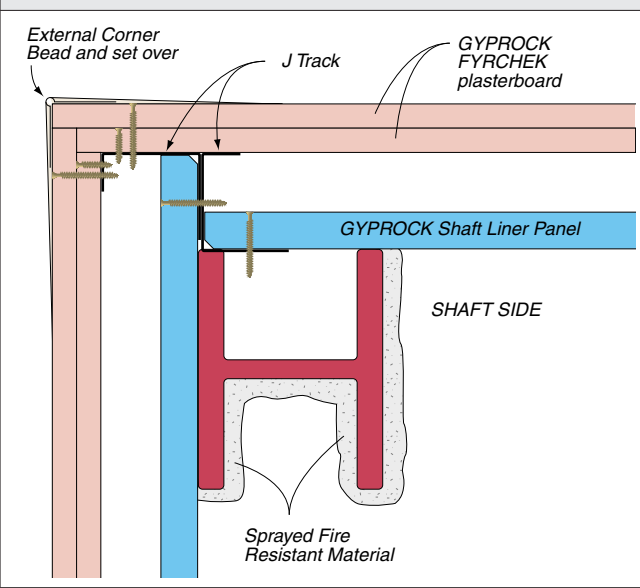

FIG 21: WALL JUNCTION AT UNIVERSAL COLUMN

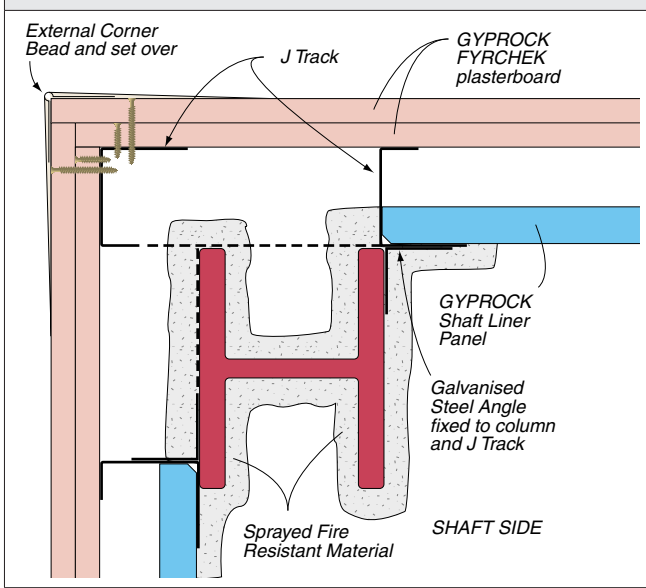

FIG 22: WALL JUNCTION AT UNIVERSAL COLUMN

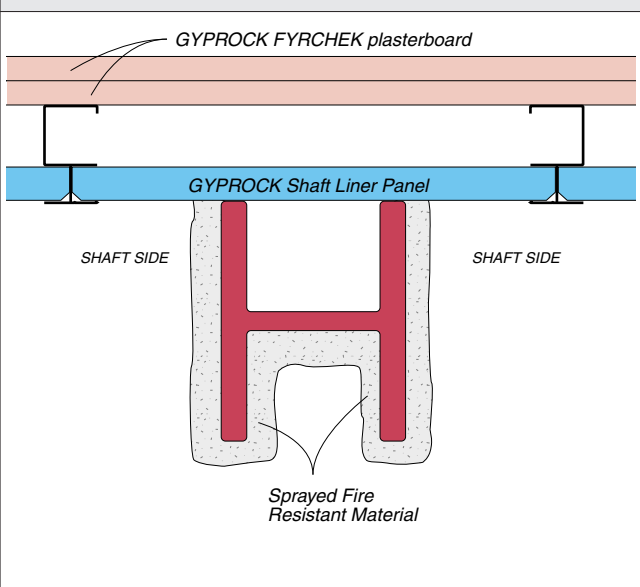

FIG 23: WALL BYPASSING UNIVERSAL COLUMN ALTERNATIVE DETAIL

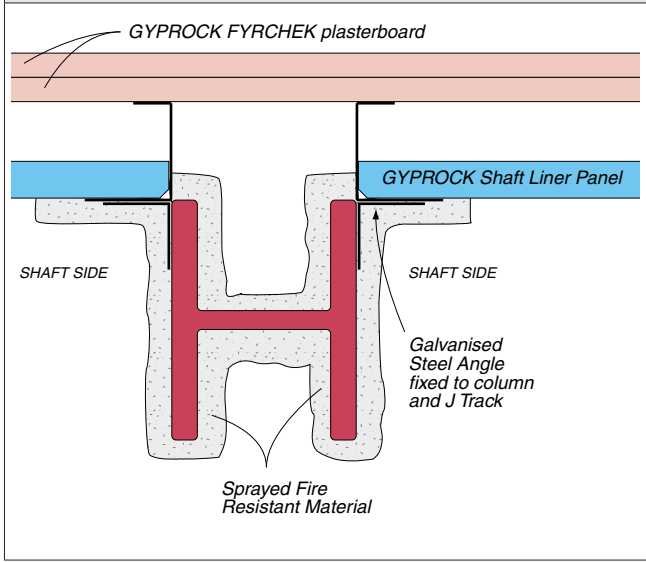

FIG 24: WALL HEAD CONNECTION TO STEEL BEAM

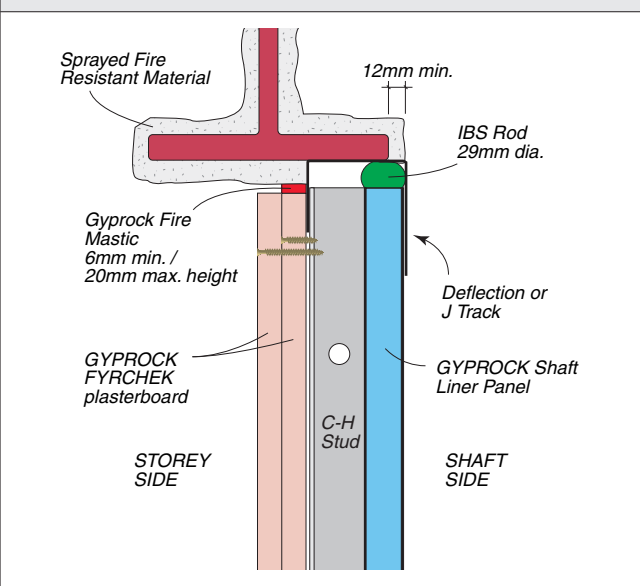
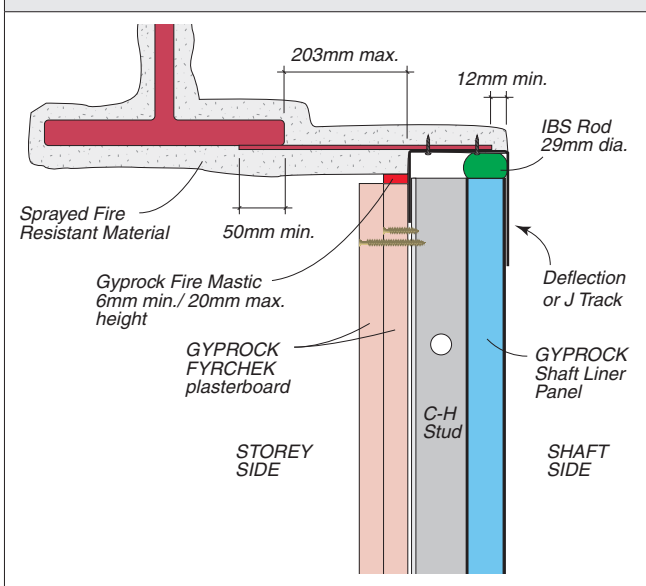
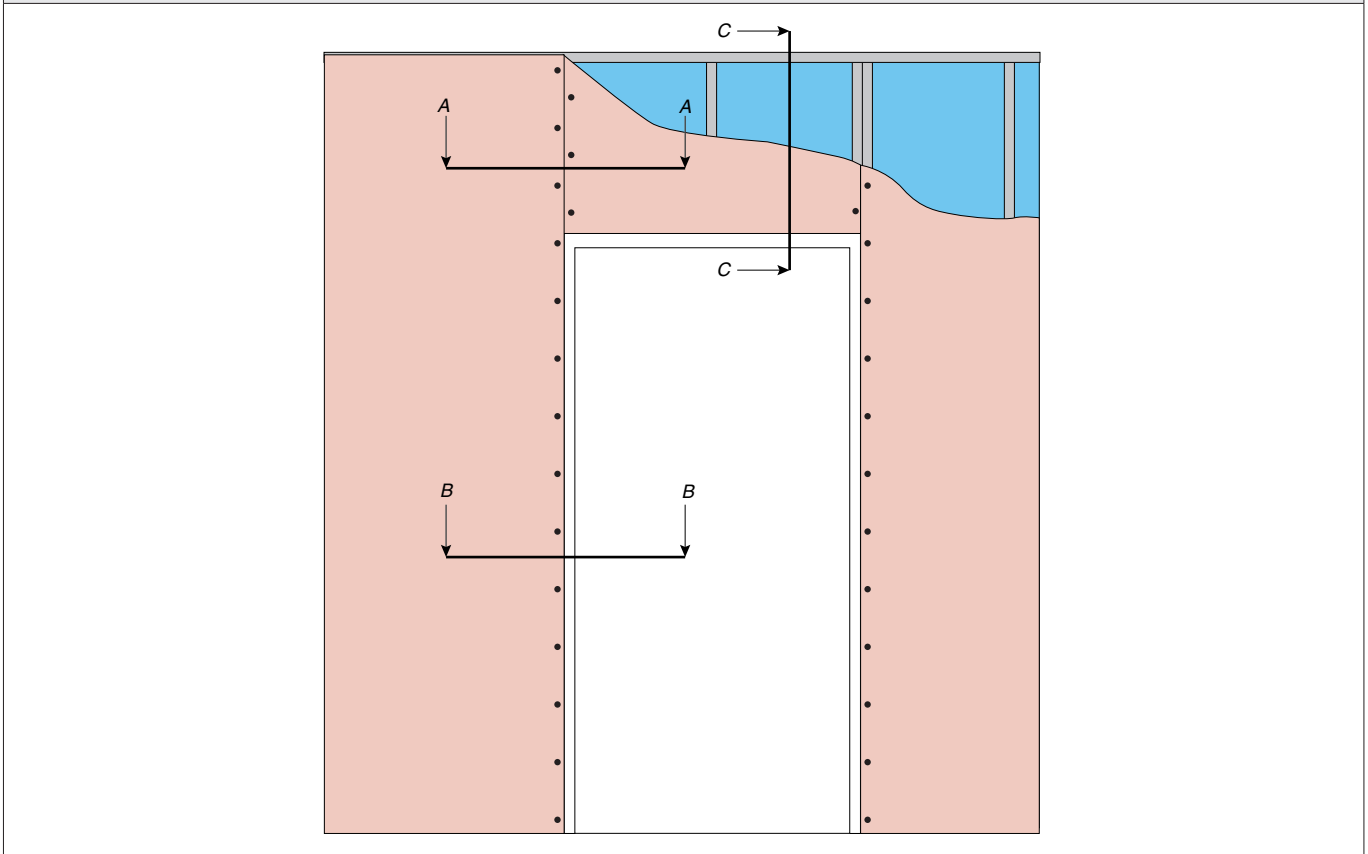

FIG 25: WALL HEAD CONNECTION TO STEEL BEAM



ACCESS DOORWAYS

FIG 26: TYPICAL STUD LOCATION AND SHEET LAYOUT



Systems CSR 970/971/977

Wall with provision for a single-leaf 2100mm high x 1080mm wide x 45mm thick side-hung fire. Refer to door manufacturer for frame filling requirements.

FIG 27: WALL SECTIONS AT DOORWAY

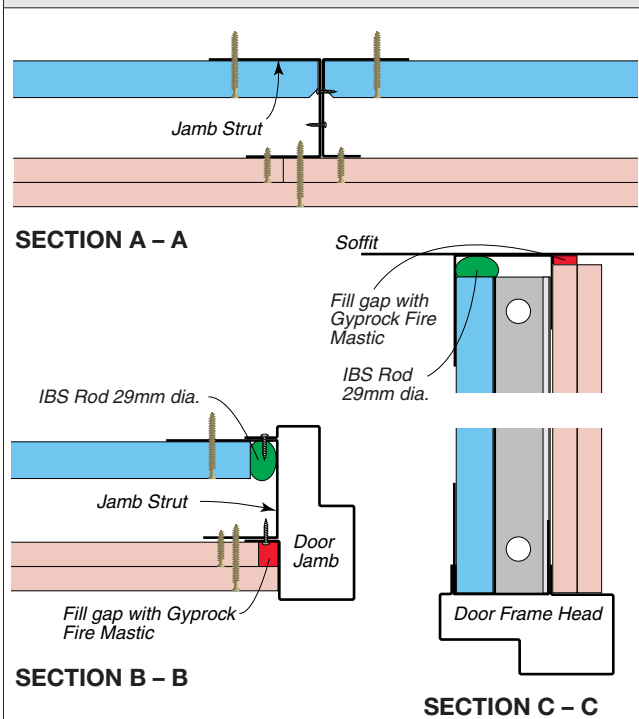

LIFT LANDING DOORWAYS

FIG 28: TYPICAL STUD LOCATION AND SHEET LAYOUT

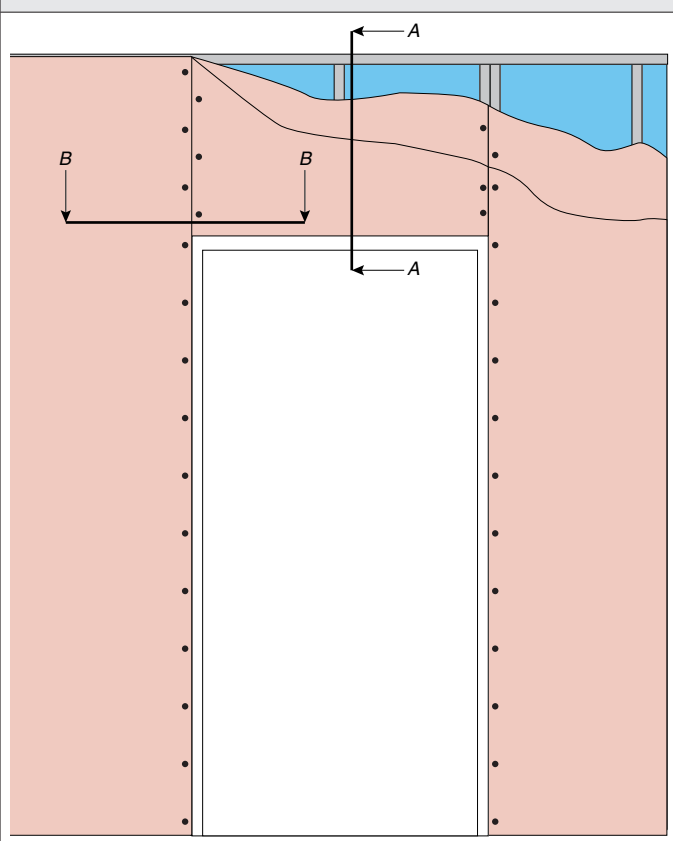

Wall with provision for side or centre opening lift landing doors.

FIG 29: TYPICAL SECTION B-B

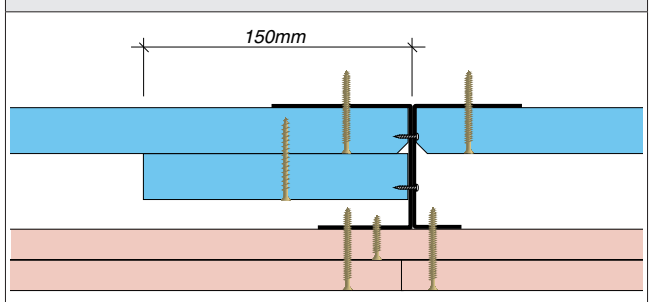
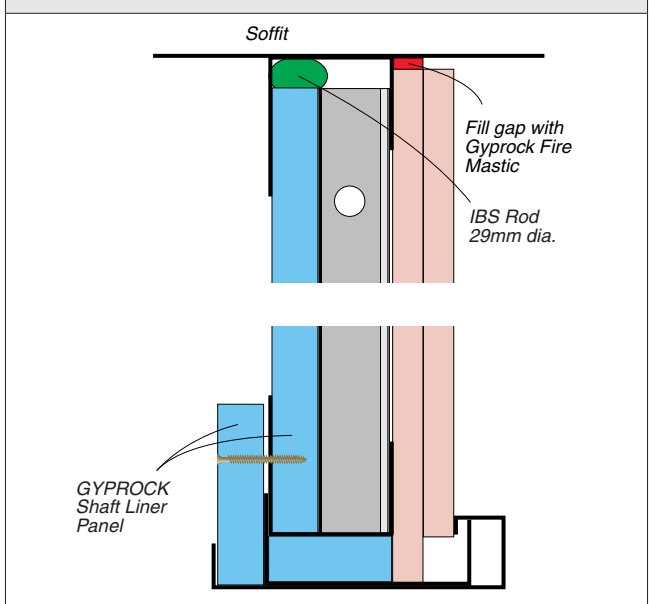

FIG 30: TYPICAL SECTION A-A



NOTE

These are typical lift door details only, as these sections vary depending on the door type and manufacturer. Refer to appropriate lift manufacturers for full details.



ACCESS PANELS & FRAMES

Gyprock™ C-H Stud Shaftwall Systems have been tested for an FRL of – /120/120 incorporating both single and multiple modular access panels and frames.

The moulded access panels and mild steel frames are manufactured by Trafalgar Fire. They are supplied to order in single or multiple modular units and include plywood faced panels.

The mild steel frames are fixed into position by the Shaftwall installer.

Panel	Max. Height	Max. Width
Single Unit	980mm	552mm
Multiple Unit	3020mm	552mm

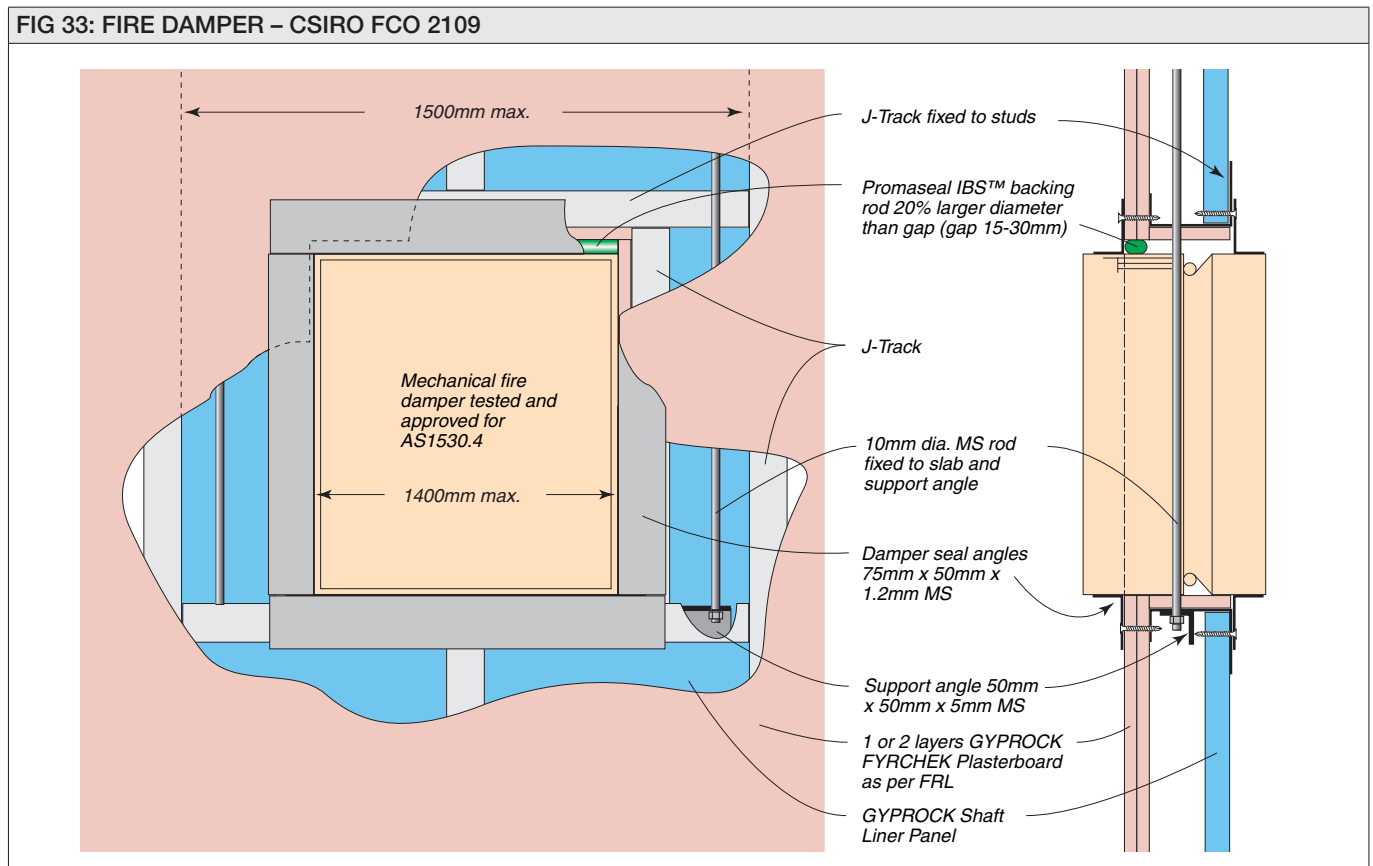
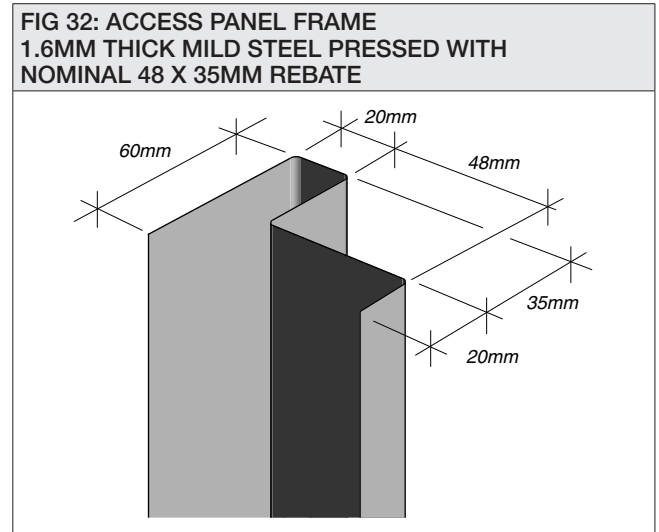
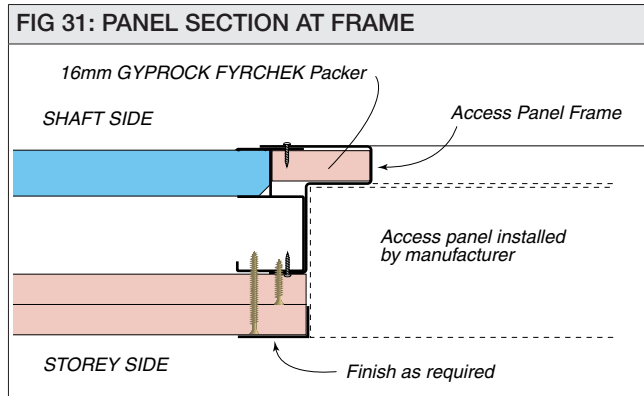

LAMINATED SERVICE SYSTEM INSTALLATION

Framing

Install steel angles over a bead of Gyprock™ Fire Mastic to floor and soffit. Align angle with the sides and ends of the required enclosure area.

Fix angles with power driven fasteners or easy drive masonry fixings at the corners and at 1200mm maximum centres between. Refer to the respective manufacturer's instructions for edge distances and safety requirements.

Install steel angles vertically at corners with a 15mm gap at the top. Fix both flanges at the top and bottom to horizontal steel angles with aluminium rivets. Where corner angles abut a masonry wall, fit angles as detailed.

Plasterboard Fixing Screw Only Installation

NOTE: The screw only fixing method is suitable for enclosures up to 1200mm width. Except at corners, no sheet joints are permitted.

Cut first layer sheets 20mm short of frame height. Install the bottom edge on the floor and fix only to the vertical corner angles at 75mm from the top and bottom and at 400mm maximum centres between. Use Gyprock™ N°6 x 25S screws.

Do not fix sheets along the top and bottom edges to the horizontal steel angles.

Install additional steel angles around the enclosure at the top, bottom and corners, and fix as for the original framing. Refer to installation details.

Fit the second layer sheets resting on the floor, leaving a 20mm gap at the top. Fix sheets to the vertical angles only as for the first layer. Fix the body of the sheet at 400mm max. vertical centres and 600mm max. horizontal centres using 40mm x N°10 Gyprock™ Laminating Screws.

Fit the third layer sheets with a 10mm gap at the bottom and a 20mm gap at the top. Fix the sheets at 75mm from top and bottom edges and corners, and at 400mm max. vertical centres and 600mm max. horizontal centres between, using 40mm x N°10 Gyprock™ Laminating Screws.

FIG 34: TYPICAL FRAME LAYOUT

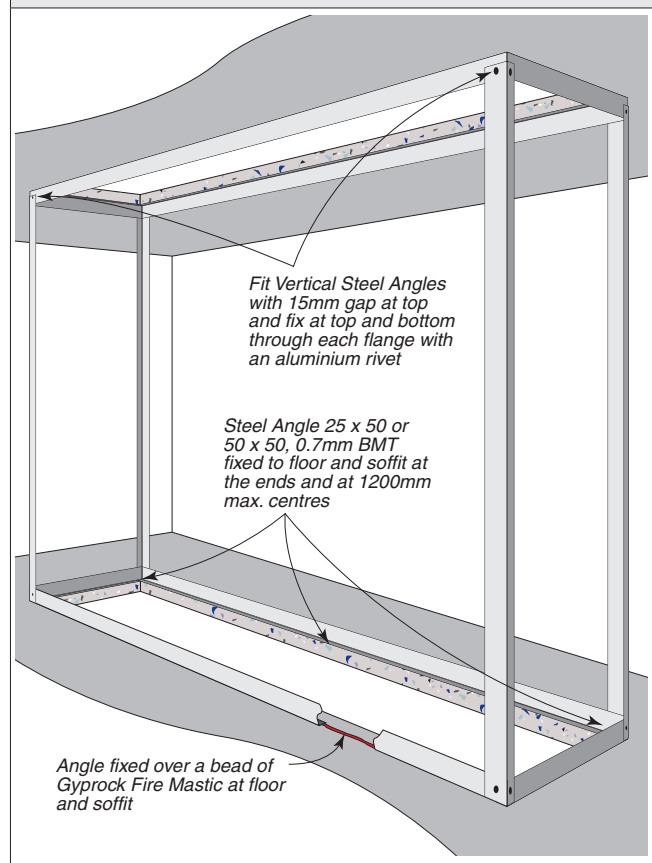

Caulk all perimeter gaps as detailed. Apply external corner bead and set corners where appropriate.

Plasterboard Fixing Screw and Adhesive Installation

NOTE: Sheet joints must be offset a minimum of 300mm from joints in the adjacent layers. The minimum width of any sheet is 300mm. Determine the appropriate sheet widths to be installed before installing the first layer.

Install the first layer as detailed for the screw only system. Prop intermediate sheets or temporarily screw to the top and bottom steel angles. Remove temporary screws before fixing the second layer.

Install additional steel angles around the enclosure at the top, bottom and corners, and fix as for the original framing, refer details.

Mix sufficient Gyprock™ Base Coat or Gyprock™ Cornice Cement to cover the wall surface. Cut the second layer sheets 20mm short of the frame height and lay them face down on a flat surface.

Using a 5mm notched trowel, cover the entire back with the chosen adhesive.

Fit the second layer sheets immediately, leaving a 20mm gap at the top. Screw fix as detailed for the second layer of the fastener only system.

Apply adhesive to the back of the third layer sheets as previously detailed and install with a 10mm gap at the bottom and a 20mm gap at the top. Screw fix as detailed for the third layer of the screw only system.

Caulk all perimeter gaps as detailed. Apply external corner bead and set corners and joints where appropriate.

FIG 35: TYPICAL FIXING – SCREW AND ADHESIVE METHOD

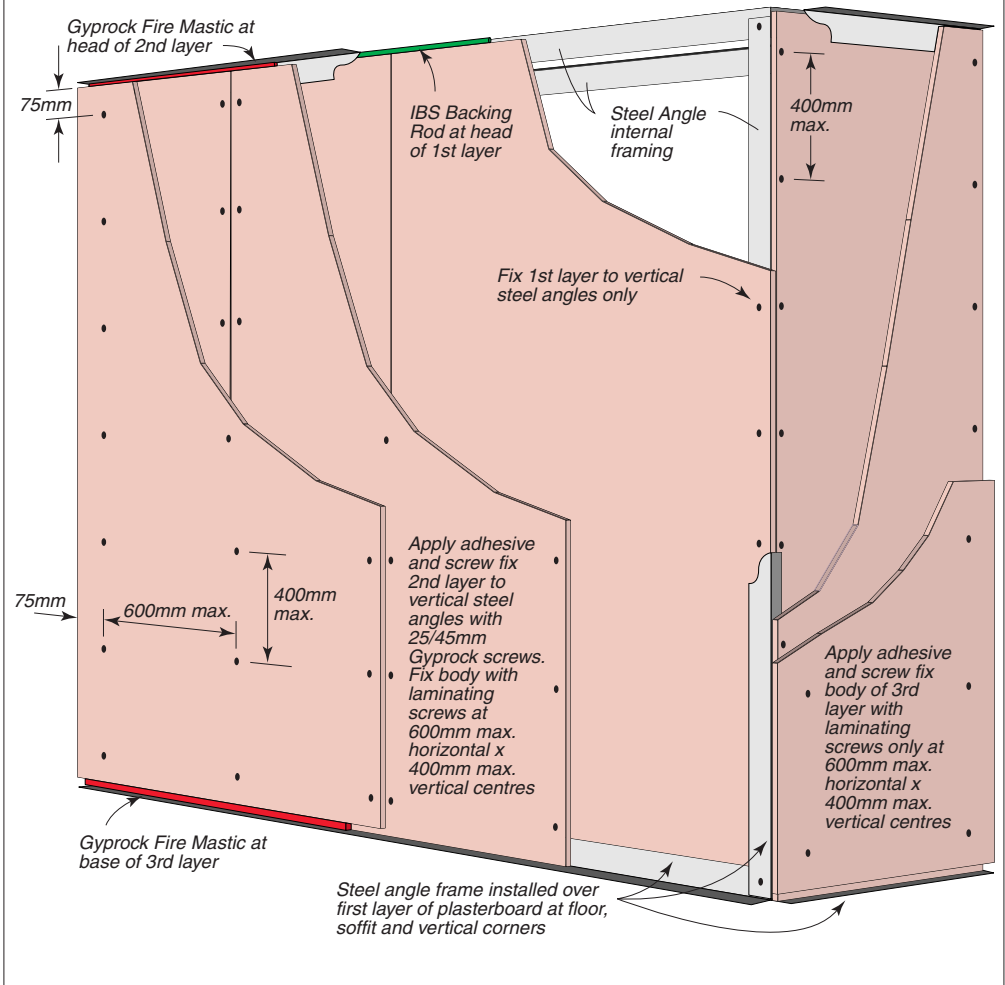

FIG 36: HEAD & BASE DETAIL

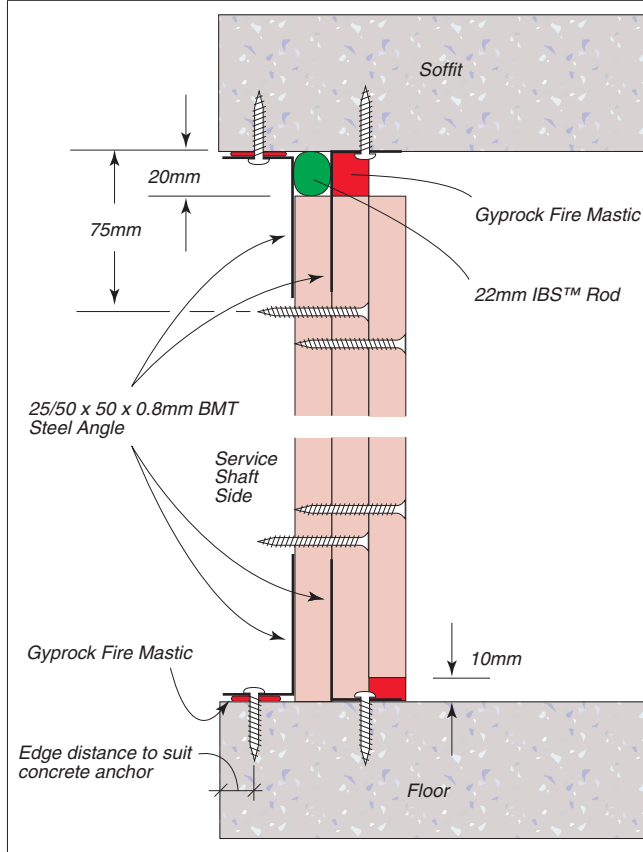

FIG 37: VERTICAL CORNER – PLAN VIEW

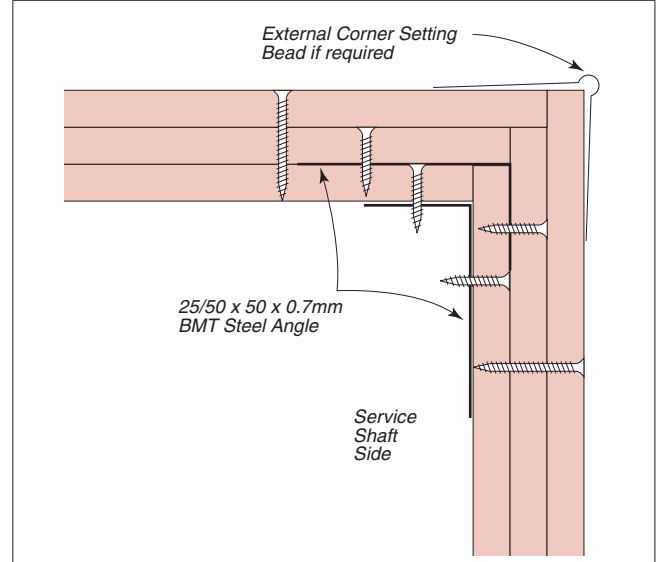

FIG 38: VERTICAL CORNER ABUTTING A MASONRY WALL DETAIL

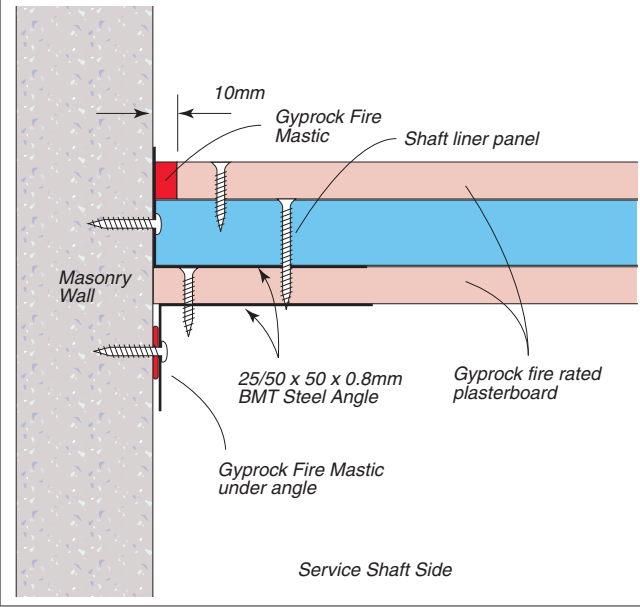

FIG 39: COPPER PIPE PENETRATION DETAIL FRL -/120/-

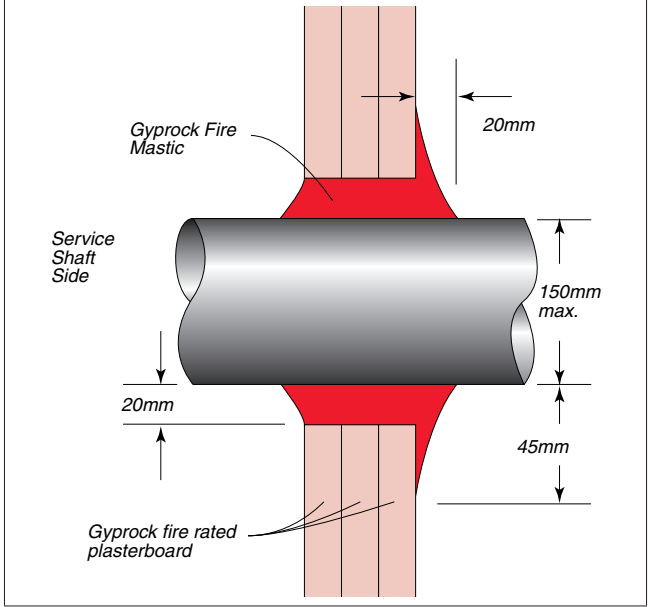

FIG 40: INSTALLATION DETAIL FOR LORIENT FIRE DAMPER

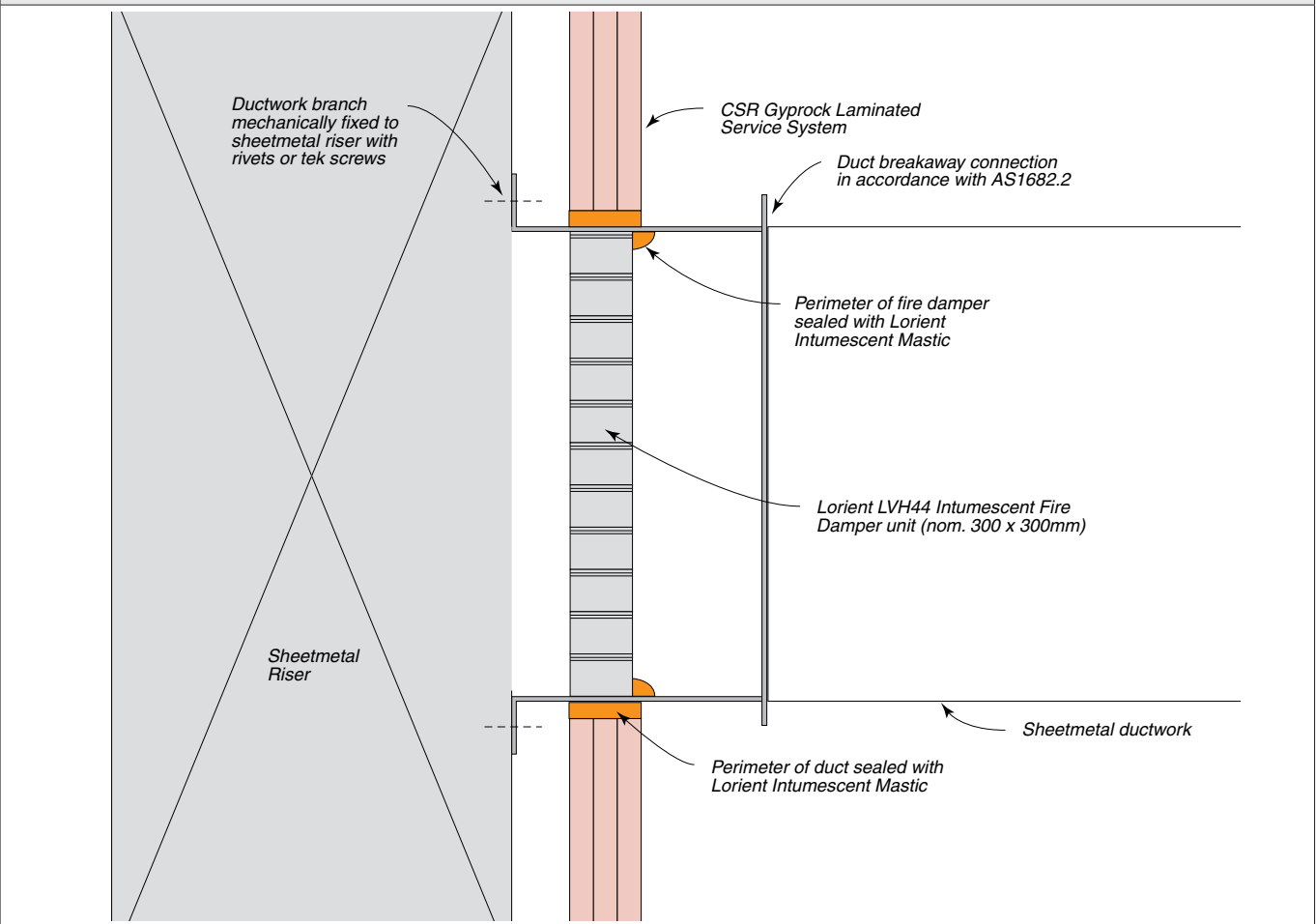
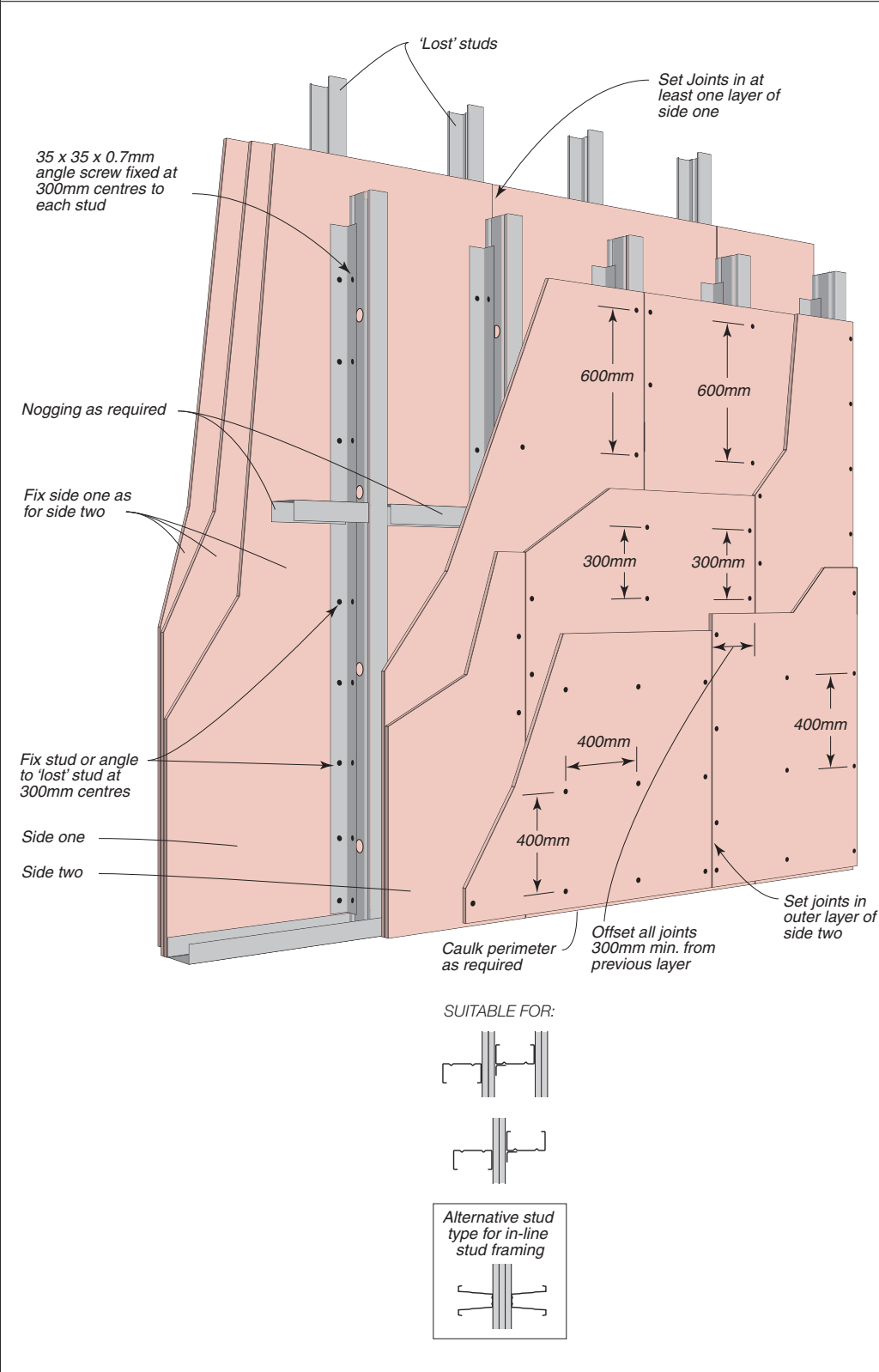

FIG 41: ALTERNATIVE INSTALLATION DETAIL FOR STEEL FRAME WALL SYSTEMS – TWO OR THREE LAYER – VERTICAL OR HORIZONTAL SHEETING



FIRE RATED

Fixing Specifications for Vertical Sheeting (shown)	
1st Layer	Fixing & Spacing
Recessed Edges, Field, Corners & Openings	#6-18 x 25mm, bugle head screws at 600mm max. centres on studs
2nd Layer	Fixing & Spacing
Recessed Edges, Field	#6-18 x 40mm, bugle head screws at 300mm max. centres on studs
Butt Joints	Laminating screws at 200mm max. centres
Corners & Openings	#6-18 x 40mm, bugle head screws at 300mm max. centres
3rd Layer	Fixing & Spacing
Recessed Edges, Field, Butt Joints, Corners & Openings	Laminating screws at 400x400mm max. grid

FIRE RATED

Fixing Specifications for Horizontal Sheeting	
1st Layer	Fixing & Spacing
Recessed Edges, Field, Butt Joints, Corners & Openings	#6-18 x 25mm, bugle head screws at 600mm max. centres on studs
2nd Layer	Fixing & Spacing
Recessed Edges	#6-18 x 40mm, bugle head screws at 600mm max. centres on studs
Field	#6-18 x 40mm, bugle head screws at 300mm max. centres on studs
Butt Joints	#6-18 x 40mm, bugle head screws at 200mm max. centres on studs
Corners & Openings	#6-18 x 40mm, bugle head screws at 300mm max. centres
3rd Layer	Fixing & Spacing
Recessed Edges, Field, Butt Joints, Corners & Openings	Laminating screws at 400x400mm max. grid

NOTE: Fix single layer systems as shown for 2nd layer

Health & Safety

Information on any known health risks of our products and how to handle them safely is on their package and/or the documentation accompanying them.

Additional information is listed in the Safety Data sheet.

To obtain a copy, telephone 1300 306 556 or visit www.gyprock.com.au.

Warranty

Gyprock products are designed to achieve optimal performance when part of a CSR integrated system.

CSR Building Products Limited warrants its Australian made Gyprock products to remain free of defects in material and manufacture for the usual lifetime of the product (25 years).

CSR warrants its International Alliance Gyprock products to remain free of defects in material and manufacture for 7 years.

For details on our product warranty, please visit www.gyprock.com.au, or contact us on 1300 306 556.

Contact Details

CSR Gyprock

www.gyprock.com.au

Telephone: 13 17 44

Facsimile: 1800 646 364

CSR DesignLINK Technical Support Service

Telephone: 1800 621 117

Facsimile: 1800 069 904

Email: designlink@csr.com.au

New South Wales and ACT

376 Victoria Street,
Wetherill Park NSW 2164

Queensland

768 Boundary Road,
Coopers Plains QLD 4108

Victoria

277 Whitehall Street,
Yarraville VIC 3013

South Australia

Lot 100 Sharp Court,
Mawson Lakes SA 5095

Western Australia

19 Sheffield Road,
Welshpool WA 6106

Tasmania

PO Box 61,
Glenorchy TAS 7010

Northern Territory

Cnr Stuart Hwy & Angliss St,
Berrimah NT 0828

GYPROCK®

Everything else is just plasterboard

Trinity 3, 39 Delhi Road, North Ryde, NSW 2113, Australia

CSR Building Products ABN 55 008 631 356



GYP546 AUGUST 2018 (BMS9849.0818)

CSR Gyprock, CSR Building Products A.B.N. 55 008 631 356.

The following are trade marks of CSR Limited and are under license. CSR, Gyprock®, Soundchek™, Aquachek™, Impactchek™, Superchek™, Fyrchek™, EC08™, Supaceil™, Bradford™, Martini™, DesignLINK™, Ceilctor™.

© CSR Limited 2018. Except as provided by the Copyright Act of 1968, no part of this publication may be reproduced in any form or by any means without the prior written permission of CSR Limited.

