

Installation Instructions



HERADESIGN® Wood Wool Direct Mount Panels



DO NOT REMOVE PRODUCT FROM THE CARTON UNTIL YOU HAVE READ THESE INSTRUCTIONS IN THEIR ENTIRETY.

1. GENERAL

1.1 Product Description





Armstrong HERADESIGN® are high performance, noise absorbing acoustical wall or ceiling panels produced from sustainable wood fibre with a magnesite binder. With multiple textures and colors to choose from, Armstrong HERADESIGN® is the perfect choice for creative design in education, sports, office, infrastructure, hospitality and recreational facilities. HERADESIGN® panels are durable and impact resistant and can be applied directly to surfaces

such as concrete or plasterboard, or via timber battens or steel stud and track. Typical panel sizes are 600 x 600mm or 1200 x 600mm, although special sizes are available upon request. Panels are either 25mm or 35mm thick.

1.2 Surface Finish

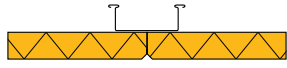
HERADESIGN® panels are available in a number of textures, with Superfine and Fine being the most common, and are finished with water-soluble (dispersion) silicate paint; typically Natural or White, although special colours are available upon request. The edges are beveled and square cut and designed to be butted together in a wall or ceiling application. The beveled edges are paint sealed, with colour to match the face.

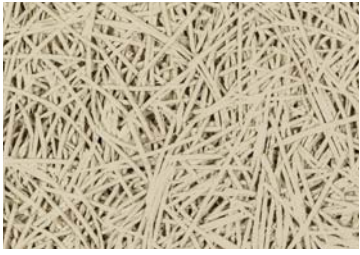
1.3 Physical Data Summary

Panel Options		PANEL SIZE (mm) ACTUAL	BEVELED (AK-01) EDGE ON ALL SIDES 25mm THICK BOARD	BEVELED (AK-01) EDGE ON ALL SIDES 35mm THICK BOARD
				
Pattern – Superfine (Fibre width 1mm) Colour – Natural		600 x 600	HSAK01060625	HSAK01060635
		1200 x 600	HSAK01120625*	HSAK01120635
			12.6 kg/m² (25mm Superfine)	16.5 kg/m² (35mm Superfine)
Pattern – Fine (Fibre width 2mm) Colour – Natural		600 x 600	HFAK01060625	HFAK01060635
		1200 x 600	HFAK01120625	HFAK01120635
			13.3 kg/m² (25mm Fine)	17.5 kg/m² (35mm Fine)

Notes: 1. Special items and other sizes available upon request. 2. For all items: Contact your local Armstrong Ceilings representative for stock availability. 3. Maximum Panel Size is 2400 x 600mm
* Stock Item

2. INSTALLATION

2.1 Transport

HERADESIGN® acoustic panels are high-quality visual panels that are carefully packed and checked and delivered to the construction site on pallets with a protective cardboard cover.

They may only be transported in closed trucks and must be protected against moisture during the entire journey.

Only stack a maximum of two pallets. Pallets and boxes must be secured against tipping, slipping and physical damage.

All material delivered to site should be checked, identifying correct: items (matching details on picking slips with product labels), correct quantities, original packages and ensuring there is no damage or opened cartons. All materials to be kept dry and protected from the elements.

If there are any transport damages, insufficient quantities, or other discrepancies to the delivery slip, have this certified by the driver.

Also, immediately inform your Armstrong office or Distributor that shipped the goods. Flawed panels must not be used.

2.2 Panel Storage

As the installing contractor, you are responsible for the proper storage of the goods at the construction site and for their transport to the installation point.

And this is how to do it correctly:

- Panels must be stored flat, on a stable floor in a dry, clean, swept-out room to protect them from moisture, soiling and dust.
- The existing packaging is no protection against rain. The panels MUST be stored in a fully enclosed environment.
- Only stack a maximum of two pallets of HERADESIGN® acoustic panels (max. height 2.5m) on top of each other.



2.3 Areas of application

- HERADESIGN® is a decorative and acoustically effective sub-ceiling and wall cladding for use in interior rooms and roofed outdoor areas, which are not exposed to direct environmental influences such as rain or pollutants.

2.4 Limitations of use

- Maximum span 625 mm (panel width)
- Suitable for rooms with a constant humidity of up to 90%.

Note: For Indoor Swimming Pools and External Soffits#, or for applications where there is a constant humidity in excess of 80% construction physics advice is recommended!

Specifically, an analysis of the temperature and humidity profile of the intended environment, structure and plenum space, with water vapour diffusion and installation of suitable vapour barrier to ensure there is no risk of condensation forming in the structure.

Note: Exterior applications must have a factory applied, or approved, exterior grade commercial paint finish.

2.5 Site Conditions & Installation

- All dust-causing construction measures must be completed and the installation environment free of construction dust and debris before starting the installation.
- Installation of HERADESIGN® acoustic panels is part of the interior fitting of the building and must only be carried out under conditions of controlled humidity and temperature.

3. WORKING WITH WOOD FIBRE PRODUCTS

3.1 Precautionary Measures

During the installation be certain that the work site is well ventilated and avoid breathing dust. If high dust levels are anticipated during installation such as with the use of power tools, use appropriate NIOSH designated dust respirator. All power cutting tools must be equipped with dust collectors. Avoid contact with skin or eyes. Wear long-sleeved, loose-fitting clothes, gloves and eye protection.

3.2 First Aid Measures

If contact occurs flush eyes and skin irritation with plenty of water for at least 15 minutes and remove contaminated clothing. After installing material, wash with warm water and mild soap. Wash work clothes separately from other clothing. Rinse washer thoroughly. Refer to Armstrong MSDS (which includes information on established occupational exposure limits) which are available from Armstrong or your employer.

3.3 Before You Start

Proper care should be taken when handling to avoid damage or soiling. White cotton or latex gloves are recommended for handling.

NOTE: Do not lean HERADESIGN® panels on an angle against the wall during installation or when field painting. This causes the panels to warp – warped panels can no longer be installed

3.4 Material and air humidity

Due to the organic component of wood, in the HERADESIGN® panels, slight deviations in the size cannot be excluded. Likewise, the panels also contract and expand if there is strongly fluctuating air humidity.

- Maximum changes in dimension in standard climate 23° C/50"% relative humidity: $\pm 1\%$.

Therefore, special attention must be given to the temperature and air humidity during installation (if necessary heat, ventilate, back-ventilate the ceiling or dehumidify the air under constant monitoring) in order to ensure constant installation conditions.

- Production tolerance for the nominal dimensions is +/- 1 mm; for lengths over 1250 mm +/- 2 mm.

3.5 Colour and structure

As a consequence of the natural raw materials of magnesite and wood, differences to the colour and structure may occur. Especially for white coloured acoustic panels, there may be changes to the degree of brightness due to the wood wool structure as well as due to the influence of light sources and the viewpoint of the observer.

Only the same type of panels may be installed in a ceiling. Therefore, constantly check the panels before installation as well as the overall impression of the ceiling from the floor.

Coloured panels (except RAL 9010) can only be ordered as specials upon request. No liability can be assumed for colour deviations in the event of partial deliveries or deviations from the colour chart.

4. UNPACKING AND HANDLING



Carefully remove the separating paper layer from the panels and dispose of it immediately. Dust lying on it must not fall onto the panel below.



Check panel for damages. Remove any remaining dust with a soft brush.



When lifting the acoustic panels from the stack, only carry them on edge. When lifting panels from the stack, never drag them over the edge of the stack in order to prevent damage to the visual side.



Never lean the acoustic panels on an angle against the wall during installation and subsequent painting. This causes the panels to warp – warped panels can no longer be installed.

5. CUTTING

5.1 Cutting and Finishing Panels:

- Eye protection should always be worn when cutting HERADESIGN® panels.
- HERADESIGN® panels may be cut with a variety of tools including table saws, circular saws, jig saws, and hand saws. A high speed circular saw with a carbide-tipped, fine tooth blade (diameter approx. 400mm) and dust extraction are recommended for all finish cuts. Sandpaper can be used to smooth the edges. Please follow the safety instructions issued by the power tool manufacturer.
- Table saw or hand saw – cut face up to minimize face chipping or damage
- Circular saw or jig saw – cut face down to minimize face chipping or damage.
- Bevels can be formed afterwards with a saw blade set on an angle, by sanding with coarse sand paper or by using a belt sander. See following illustrations. If possible, the finishing work should be carried out outdoors. Always work with clean hands and clean tools. Cut the panels such that the visual surfaces are not dirtied by saw dust.
- The cutting must not be done using the stack of panels as a base.
- Carefully cover minor damages and screw heads, edges and panel surfaces with paint after installation. Only apply a small amount of paint to avoid colour differences.
- Installation methods with cross joints are difficult to use (Four panel corners at one point is laborious).



Not this way! – Never cut acoustic panels on a stack.



Table saw – Lay the acoustic panel down with the exposed side up. Always work with a safety guard, guide and an extraction system.



Jack saw – Lay the acoustic panel down with the exposed side up. Always work with a guide. Support the free end of the panel.



Circular saw – Lay the acoustic panel down with the exposed side down. Always work with a guide and an extraction system. Support the free end of the panel.



Jigsaw – Lay the acoustic panel down with the exposed side down. Always make longitudinal cuts with a guide.



Cutting openings by means of a supercutter – Only cut at a right angle to the panel surface.

6. MOUNTING

- **Before you start mounting**, check the structure for sufficient load-bearing capacity (refer to panel weights on page 1).
 - **Suspension Systems:** Timber Battens, Suspended Top Cross Rails (TCR's) and Furring Channels, or equivalent must be installed in accordance with the manufacturers guidelines, and according to Australian Standards.
 - **Evenness:** the greatest deviation from the evenness of the substructure may only be a maximum of 2mm per meter of length; however, it must not exceed 5mm over a length of 5.0m. EN 13964, Section A.5.
 - **Expansion Joints:** for large ceiling areas that are installed with screw mounting in areas or in rooms with strongly changing high air humidity (rel. air hum. > 80%), we recommend placing an expansion joint at least every 15m. The expansion joint must be formed between the substructure and the HERADESIGN® acoustic panel. When connecting these ceilings to fixed limiting structural elements, care must also be given to sufficient expansion possibilities. Here, the free edge distance should be at least 10mm.
 - **Vibrating structural elements:** suspended ceilings with insertion or screw mounting in which angularly flexible hangers are fastened to structures that tend to have vibrations such as trapezoidal sheet metal roofs, steel or wood binders/trusses, must be secured by hangers placed on an angle (at least 10% of them) to counter horizontal displacement. For screw installation, at least three screws must be used per panel width and support.
 - **Resistance to wind loads:** If it is to be expected that suspended ceilings will be subject to wind loads (e.g. by open windows, doors), then the appropriate measures must be taken to ensure that the top layer and the substructure can withstand suction and/or pressure wind loads.
 - **Panel Directionality:** The installation direction must be observed for square panels. This is identified by an arrow on the panel backside. Always install with the arrow in the same direction.
 - **Maximum span** of the panel: 625mm.
 - **Vapour Barrier** (thickness < approx. 25 m) is recommended as moisture protection for insulation backing.
- Please note: HERADESIGN® acoustic panels are generally not suitable for glue mounting. A combination of gluing and screwing must also not be used.



Aligning the Grid with a spirit level or laser level.



Finished ceiling grid.

7. MOUNTING METHODS

HERADESIGN® panels can be installed by mechanically fastening the panels to either wood or metal furring or directly to a structure. As the weight of the panels can vary based on thickness and face pattern, special consideration should be taken to determine the type of fastener that is required (see Table 1, on page 1).

The use of Drywall Grid or Top Cross Rails and Furring Channels not only makes the installation easier for the installer, but also improves sound absorption by using the air gap between the panel and structure or by installing insulation behind the panel. The NRC requirement of the project will determine what mounting method will be used. The nature of HERADESIGN® panels and the face pattern makes the use of screws an acceptable fastener method. When installed properly, the head of the screw is difficult to see after installation.

Do not countersink the screw heads. Screws are to be installed flush with the surface of the HERADESIGN® panels and can be field painted.

The following sections outline the various mounting methods and fastener recommendations.

7.1 Screw Specification

Armstrong HERADESIGN® panels are to be installed to timber battens, furring channels or Drywall Grid with Rust-protected, universal drywall screws with dimensions below:



Panel Thickness	25mm	35mm
Screw Dimension (diameter x length)	4.5 x 50mm	4.5 x 60mm

7.2 Screw Fixing the HERADESIGN® Panel to Steel Furring Channels or Timber Battens

Screws are to be located no closer than 20mm to the panel edge. This will require a steel batten with face > 50mm or a timber batten with face of 60mm minimum.

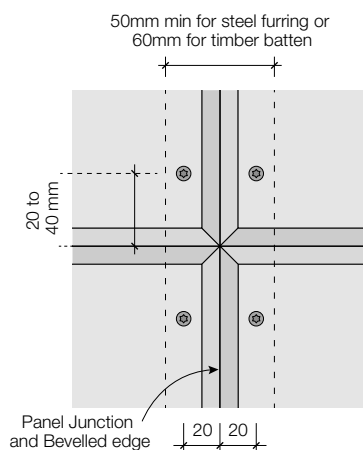

7.3 Direct Mount Method for Walls

Mounting A NRC 0.55 (25mm)
NRC 0.65 (35mm)

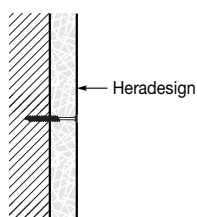

Installed Directly on a Wall or Ceiling Surface

Mounting D NRC 0.50 (25mm)
NRC 0.55 (35mm)

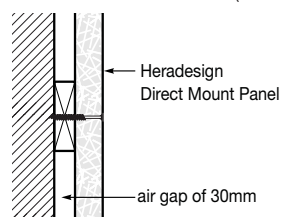

Installed on Timber Batten or Furring Channel: 600mm O.C.

Mounting C NRC 0.80 (25mm)
NRC 0.85 (35mm)

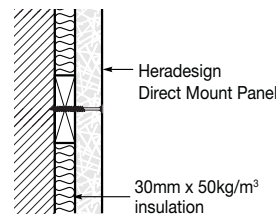

Installed on Timber Batten or Furring Channel: 600mm O.C.

Mounting C NRC 0.95 (25mm)
NRC 0.90 (35mm)

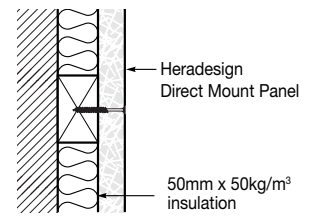

Installed on Timber Batten or Furring Channel: 600mm O.C.

Mounting A

As ceiling and wall structure materials vary from project to project, it is recommended that the contractor work with fastener manufacturers to determine the best fastener for the specific application and engineering support information that will meet the pull-out requirements for the building code.

NOTE: For panels that are being fastened directly to a Masonry structure use masonry screws.

Do not use power actuated fasteners to directly attach HERADESIGN® panels to masonry surfaces

Mounting D and C

The attachment of the timber batten or furring channel to the structure and the type of channel must be designed to support the weight of the HERADESIGN® panels being used. Please refer to page 1 for panel weights. Battens or furring channels are to be spaced not over 600mm o.c. and perpendicular to the panel direction.

It is the responsibility of the installing contractor to ensure that furring installed on existing plasterboard is mechanically fastened to a stud, drywall grid, or other structural component.

7.4 Screw Location

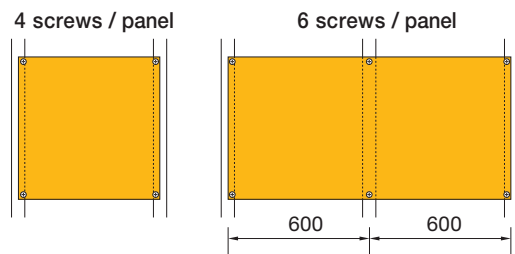

Standard Screw Pattern for Mounting HERADESIGN® Acoustic Panels of 25mm or 35mm thickness

7.5 Panel Configuration

It is recommended that HERADESIGN® panels are installed using a "brickwork" pattern (joints staggered), this will help with the ease of installation. Important, if installing with cross joints (4 panel corners meeting at one point) increased accuracy is required.

Panel Layout for Wall Application

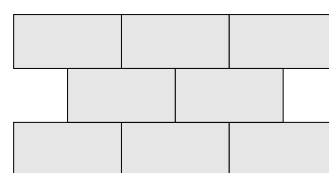

Horizontal

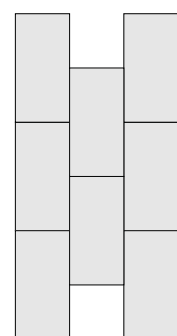

Vertical

- Battens or Furring Channel installation perpendicular to long edge of panel
- Stagger end joints and install panels beveled edge to beveled edge
- Battens or Furring Channels are required at the ends of the panels

7.6 Direct Mount Method for Ceilings

Timber Battens or Top Cross Rail / Furring Channels or equal are to be used to support Heradesign panels.

When installing HERADESIGN® panels in a ceiling application follow the same fastener and mounting methods shown for walls. Screw fixing should be spaced at 600mm centres maximum regardless of metal or timber construction. See 7.7 for Ball Impact applications.

Install metal furring or timber suspension rails perpendicular to the panel direction at no more than 600mm o.c. Ensure panel edges extend over the battens or furring channels. As with wall applications, HERADESIGN® installed in ceiling applications must be installed in a “brickwork” pattern (staggered end joints).

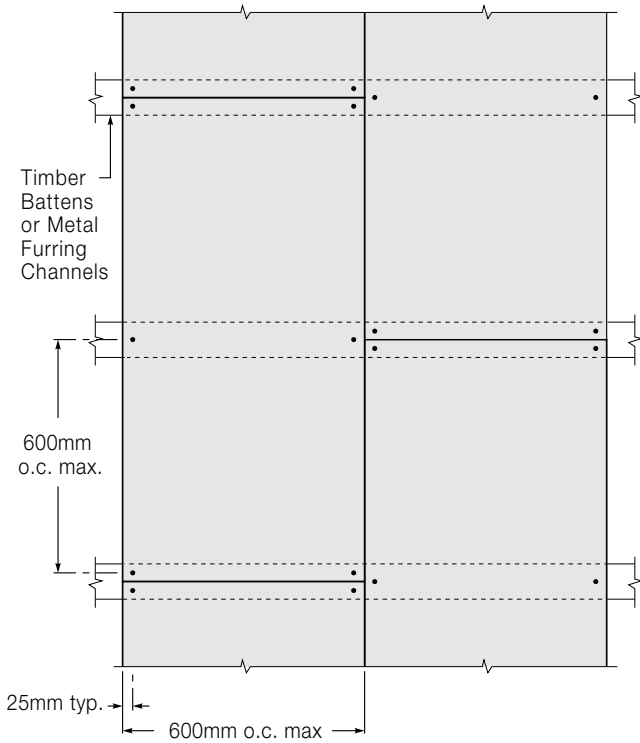

Install screws every 600mm o.c. to furring ensuring screw heads are flush with the face of HERADESIGN® panels. Do not countersink screws. Ensure that any time two panels abut against one another the edges are beveled.

Install the next panel against the furring, gently butt the end to the previously installed panel and fasten every 600mm o.c.

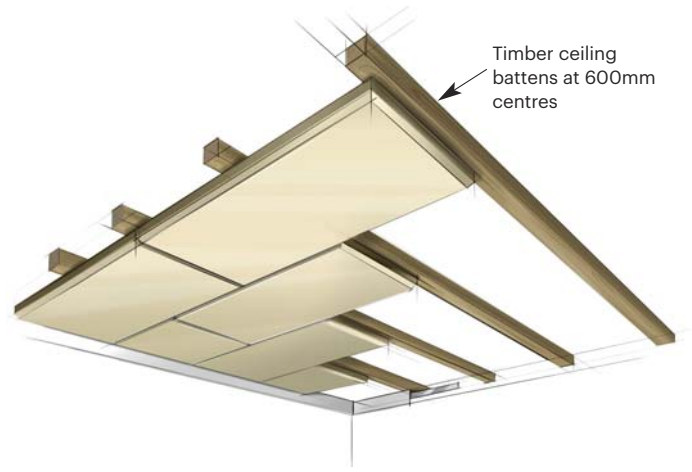
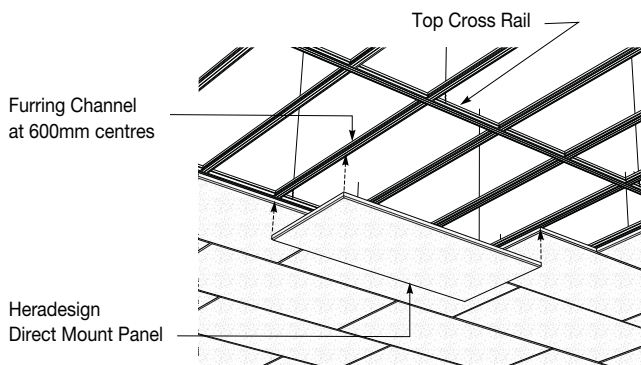

Installing the first row of panels: always start installing from the centre of the room, which has been pre-marked. Exactly align the panels in longitudinal and transverse direction.



Positioning the screws or the acoustic panels with auxiliary lath. Make sure that there is enough space at the end of the panel to prevent the edge from displacing. Make sure the screw head is flush to the surface of the panel. The auxiliary lath is removed after installing the first row of panels. Screw pattern, see pages 5, 6 and 7.



Not this way! – The screw head must be flush with the surface of the panel. A depth gauge should be used to prevent the over-driving of screws into the face of the panel.



Install the acoustic panels by means of supports. Press the panel onto the section with the ball of your hand while screwing. There must not be a gap between the acoustic panel and the section. Start panel installation from the centre of the room. Only work with the acoustic panels with clean hands and clean tools.



Align the panel rows with an installation lath. Panel joints must be positioned to be centred under the section. No free, suspended panel joints are allowed. When installing square panels, observe the installation direction marked on the back of the panels.

7.7 Ball Impact Applications (such as gymnasiums)

For ball impact resistant fixing of HERADESIGN® acoustic tiles, at least three screws must be used per tile width and support.

Maximum screw centres ≤ 300 mm. This also applies to any vibrating construction.

Ceiling installation: 25mm and 35mm tiles

Wall installation: 35mm tiles

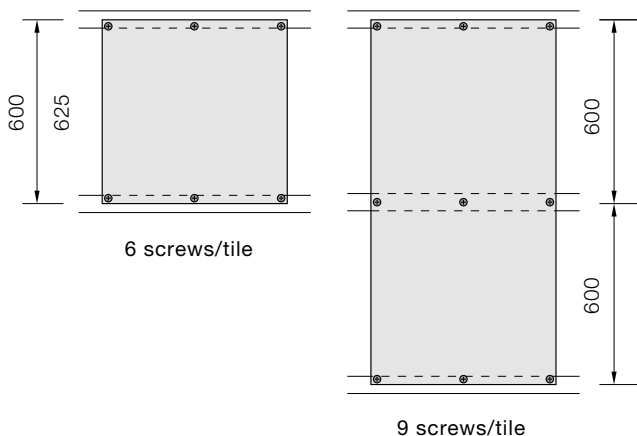

Wall installation: 25mm tiles*

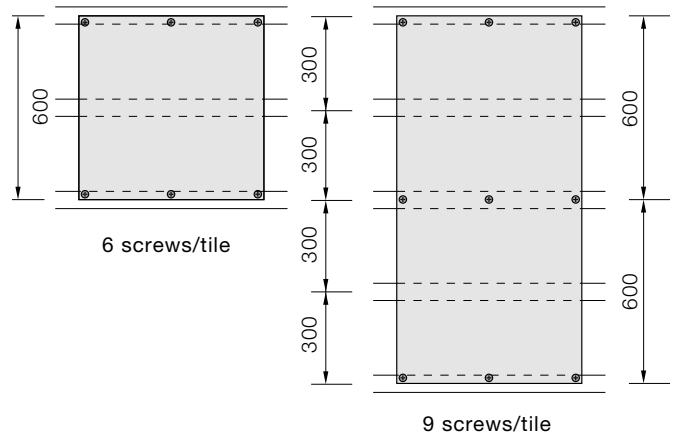

* For wall installation of 25mm HERADESIGN® tiles, the main batten centres are reduced to 300mm. The position and number of the screws remains the same.

8. PAINTING AND CLEAN UP

8.1 Field Painting or Re-Painting of HERADESIGN® Panels

For subsequent painting of HERADESIGN® acoustic tiles, there is a distinction between painting or re-painting the tiles and improvement of surface damage as well as unevenness and refreshing paint. For factory painted HERADESIGN® wood wool tiles, a water-soluble (dispersion) silicate paint with potassium silicate and co-polymerisates as bonding agents is used. Therefore, the composition of the new paint must be compatible with the existing paint and be of the same quality as the specified and tested reference paints.

For the following applications, the following quantities are recommended:

HERADESIGN® panels are interior finishes and a commercial grade acrylic dispersion paint, tested for harmful substances is recommended for "Field Painting or Re-Painting" as follows.

Note: Exterior applications must have a factory applied, or approved, exterior grade commercial paint finish.

- **White paint on a white surface (restoration):**
Quantity: approx. 0.20 l/m², one coat
- **Restoring other colours with the same colour (except white):** Quantity: approx. 0.20 – 0.25 l/m², one coat
- **Painting or changing colours of wood wool tiles:**
Bold or contrasting colours may require increased quantities
Quantity: approx. 0.25 – 0.30 l/m² per coat, min. two coats
- **Small area repair of metallic colours:**
Recommended product: Sto Color Metallic or equivalent

Protective measures for bordering surfaces, floors, etc.

Bordering surfaces, windows, floors, etc. must be covered. Water can be used to clean surfaces that have been dirtied with paint, while they are still wet. Dried paint can only be removed with a paint stripper and that may cause damage to the underlying surface.

Safety:

Follow the information regarding protective measures in the safety data sheets from the paint manufacturer. If necessary, protect your head, eyes, respiratory system and skin by wearing protective masks, goggles, gloves and work clothing.

Types of application:

a) Painting or changing colours of wood wool tiles:

In order to achieve sufficiently deep penetration of the paint in the wood wool texture, the paint must be applied with an airless sprayer. The paint should be applied in at

least two different directions and at varying angles to the tile surface so that the colour penetrates all pores and openings. When applying two coats, the first coat must be dry before the second coat is applied.

b) Refreshing paint and improving paint deviations:

For refreshing paint, improving paint deviations and painting the fibres, a short-pile roller can be used for small areas or for the same or very similar colours. Well suited are for example:

- Glaze or varnish rollers with max. pile depth 13 mm (e.g.: Microfibre rollers 13 mm, glaze rollers 10 mm, etc.)
- Flock rollers

c) Improving damaged or uneven surfaces:

To even out gloss differences in the same colour tones, foam rollers (paint rollers) are suitable.

d) Painting screw heads and improving slight damage to the surface e.g. single fibre breaks):

The screws and individual fibres can be covered with a fine brush. Avoid double painting the tile surface.

e) Painting bevels:

The paint can be applied with a short-pile paint roller (as described in point b), or by brush. Avoid double painting the tile surface.



Painting over the screw heads – Use a fine brush to cover unpainted screw heads with the colour of the panels after installation. It is absolutely necessary to avoid double painting of the panel surface around the screw head. This would cause irritating colour differences.



Edge touch-up – Cover cut edges with paint if these are not concealed by a cover.



Creating the edge bevel – The bevel is formed with coarse sand paper, belt sander or a saw blade set on an angle.



Brushing – Efflorescence, dust, etc. can be removed with a soft brush. Set loose fibres with a commercial grade acrylic primer.



Remove any dust with a soft brush.



Chipped fibre – Cover chipped fibre with a fine brush or a spray gun using the supplied paint or an equivalent.



Painting the bevel – Use a brush or a thin paint roller to apply the paint.

HERADESIGN® Wood Wool Direct Mount Panels



Touching-up chipped fibre or small, unclean areas of the panels – The paint is sprayed on carefully with a spray gun using various spraying angles.

Note:

Always apply only the recommended quantities. Too much paint causes excessive moisture to be added and can cause the tiles to warp and swell as well as causing a reduction of the sound absorption of the tiles. Up to three proper paint applications (quantity and application) of HERADESIGN® superfine and HERADESIGN® fine, leads to no significant decrease in sound absorption.

The application of the paint and the coverage must be checked constantly from the floor. The manufacturers' regulations and instruction manuals must be observed when working with the paint and operating the equipment. For application variants b) and c) a paint roller grid should be used to ensure the paint is evenly distributed on the roller. To avoid clogging the wood wool texture, only light pressure should be applied to the tile. The application should be done cross-wise. It is recommended to test the colour first (hidden tile or sample tile). Deep penetration of the paint in the texture, as necessary when changing the colour of the tile, is only possible with an airless spray application.

MORE INFORMATION

For complete technical information, detail drawings, CAD design assistance, installation information and many other technical services, call your local Armstrong Ceilings representative.

For the latest product selection and specification data, visit armstrongceilings.com.au

Contact us

NSW/ACT

Armstrong Ceiling Solutions (Australia) Pty. Ltd.
Unit 4, 1 Basalt Road, Pemulwuy NSW 2145
Telephone (02) 9748 1588

VIC/TAS

Armstrong Ceiling Solutions (Australia) Pty. Ltd.
Unit 1, 88 Henderson Road, Rowville VIC 3178
Telephone (03) 8706 4000

QLD / NT

Armstrong Ceiling Solutions (Australia) Pty. Ltd.
6 Barrinia Street, Slacks Creek QLD 4127
Telephone (07) 3809 5565

SA

Total Building Systems Pty. Ltd.
160 Grand Junction Road, Blair Athol SA 5084
Telephone (08) 7325 7555

WA

Ceiling Manufacturers of Australia Pty. Ltd.
3 Irvine Street, Bayswater WA 6053
Telephone (08) 9271 0777

New Zealand

Forman Building Systems Ltd.
27B Smales Road, East Tamaki, Auckland 2013
Telephone 64-9-276 4000

